

15 W and 25 W “Mega-Zenigata”

Application Note

February 2011

This Factory Application Note details special electrical and optical considerations when designing with the GW5DxxxxMxx Mega-Zenigata LEDs.

SHARP Mega-Zenigata 15W and 25W class LEDs

-Application Note-

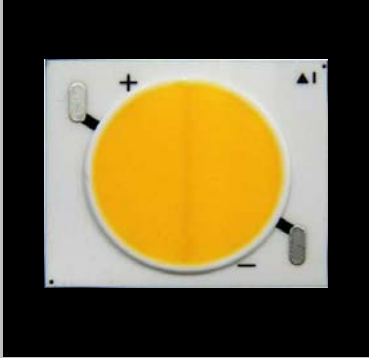

Abstracts

This application note is intended to help designs with the special electrical and optical considerations of the GW5D****M** Mega-Zenigata LED.

GW5D****M**

The Sharp LED GW5D****M** Mega-Zenigata 15W and 25W class high performance and efficiency, compact solid-state lighting solutions the general lighting. Life-time and reliability benefits of LEDs.

Features

- 15W and 25W class high-power LED
- Space saving and high performance LED, dimensions - 20.0x24.0x1.8t mm
- Based on ceramic substrate to achieve long operating life
- Binning - Chromaticity
- Typical luminous flux performance 2,300~2,600lm@700mA (25W class)/ 1,350~1,550lm@400mA
- Typical viewing angle : 120°
- High color rendering index $Ra \geq$ Typ. 90 (High CRI type)
- Chromaticity - smaller than ANSI C78-377-2008 compliant
- Narrow and Easy-to-use Chromaticity binning
- RoHS compliant
- Protection circuit for reverse bias
- Possible to attach to heat sink directly without using print circuit board.

Applications

- Indoor & outdoor lighting
- Downlights
- Spotlights
- Stage lighting
- Street light
- Alley light

Materials

Items	Description
Substrate	Alumina Ceramic
Encapsulating Resin	Silicone resin
Electrodes	Ag, Pt
Die attach resin	Silicone paste
LED die	InGaN

Table of contents

GW5D****M**

<u>Contents</u>		<u>Page</u>
Products lineup	...	3
Absolute maximum ratings	...	4
Chromaticity binning	...	5~10
Emission spectrum	...	11~16
Temperature characteristics	...	17
Derating curves	...	18
Electrical characteristics	...	19
Reliability test data	...	20
Flux distribution characteristics	...	21
Appearance	...	22,23
Protection circuit function	...	24,25
Thermal resistance	...	26~28
Heat design	...	29,30
Handling	...	31
How to mounting	...	32
Instruction	...	33,34
Optics	...	35~37
Revision record	...	38

Products lineup

GW5D****M**

Part No. definition

G W 5 D - * - * - * * - M * *

G: High CRI Model	C:25W	27 : CCT = 2700K	Administration number
M: 2700~3500K	A:15W	30 : CCT = 3000K	
L : 4000~6500K		35 : CCT = 3500K	
		40 : CCT = 4000K	
		50 : CCT = 5000K	
		65 : CCT = 6500K	

The table describe the available colors and flux for GW5D****M** by correlated color temperature by base part number.

Note that the base order codes listed here are subset of the total available order codes for the product family.

For more order codes, as well as a complete description of the order-code nomenclature, please consult the GW5D****M** binning and labeling document.

T_c=25°C

Color	Drive current	CCT range		CRI		Flux (lm)		Forward voltage (V)		Part Number
		min.	max.	min.	typ.	typ.	typ.	max.		
CW	700mA	6020	7040	80	82	2600	37.0	41.0	GW5DLC65M04	
NW	700mA	4745	5311	80	82	2600	37.0	41.0	GW5DLC50M04	
NW	700mA	3900	4200	80	82	2550	37.0	41.0	GW5DLC40M04	
NW	700mA	3300	3600	80	83	2450	37.0	41.0	GW5DMC35M04	
WW	700mA	2900	3150	80	83	2370	37.0	41.0	GW5DMC30M04	
WW	700mA	2600	2800	80	83	2300	37.0	41.0	GW5DMC27M04	
CW	700mA	6020	7040	-	90	2080	37.0	41.0	GW5DGC65M04	
NW	700mA	4745	5311	-	90	2080	37.0	41.0	GW5DGC50M04	
NW	700mA	3900	4200	90	92	2050	37.0	41.0	GW5DGC40M04	
NW	700mA	3300	3600	90	92	1990	37.0	41.0	GW5DGC35M04	
WW	700mA	2900	3150	90	93	1950	37.0	41.0	GW5DGC30M04	
WW	700mA	2600	2800	90	93	1910	37.0	41.0	GW5DGC27M04	
CW	400mA	6020	7040	80	82	1550	37.0	41.0	GW5DLA65M04	
NW	400mA	4745	5311	80	82	1550	37.0	41.0	GW5DLA50M04	
NW	400mA	3900	4200	80	82	1520	37.0	41.0	GW5DLA40M04	
NW	400mA	3300	3600	80	83	1450	37.0	41.0	GW5DMA35M04	
WW	400mA	2900	3150	80	83	1400	37.0	41.0	GW5DMA30M04	
WW	400mA	2600	2800	80	83	1350	37.0	41.0	GW5DMA27M04	
CW	400mA	6020	7040	-	90	1250	37.0	41.0	GW5DGA65M04	
NW	400mA	4745	5311	-	90	1250	37.0	41.0	GW5DGA50M04	
NW	400mA	3900	4200	90	92	1230	37.0	41.0	GW5DGA40M04	
NW	400mA	3300	3600	90	93	1200	37.0	41.0	GW5DGA35M04	
WW	400mA	2900	3150	90	93	1170	37.0	41.0	GW5DGA30M04	
WW	400mA	2600	2800	90	93	1150	37.0	41.0	GW5DGA27M04	

*CW = Cool White, NW = Natural White, WW = Warm White

Absolute maximum ratings

GW5D***M**

Absolute maximum ratings

1. For all GW5D*C**M** products family

Parameter	Symbol	Rating	Unit
Power dissipation *1,4	P	30.8	W
Forward current *1,4	IF	770	mA
Reverse voltage *2,4	VR	-15	V
Operating temperature *3	Topr	-30~+100	°C
Storage temperature	Tstg	-40~+100	°C

2. For all GW5D*A**M** products family

Parameter	Symbol	Rating	Unit
Power dissipation *1,4	P	18.0	W
Forward current *1,4	IF	450	mA
Reverse voltage *2,4	VR	-15	V
Operating temperature *3	Topr	-30~+100	°C
Storage temperature	Tstg	-40~+100	°C

- *1 Power dissipation and forward current are the value when the module temperature is set lower than the rating by using an adequate heat sink.
- *2 Voltage resistible at initial connection error
(Not dealing with the possibility of always-on reverse voltage)
- *3 Case temperature Tc (Refer to measuring point for case temperature in the page 29)
- *4 Tc=25°C

Chromaticity binning

GW5D****M**

GW5D**65M** CCT=6500K Chromaticity binning

GW5D*A65M** (IF=400mA, Tc=25°C)

GW5D*C65M** (IF=700mA, Tc=25°C)

Rank	Point 1		Point 2		Point 3		Point 4	
	x	y	x	y	x	y	x	y
1	0.3028	0.3304	0.3058	0.3161	0.3138	0.3238	0.3117	0.3393
2	0.3117	0.3393	0.3138	0.3238	0.3217	0.3316	0.3205	0.3481

Chromaticity Diagram

Tolerance x,y ±0.005

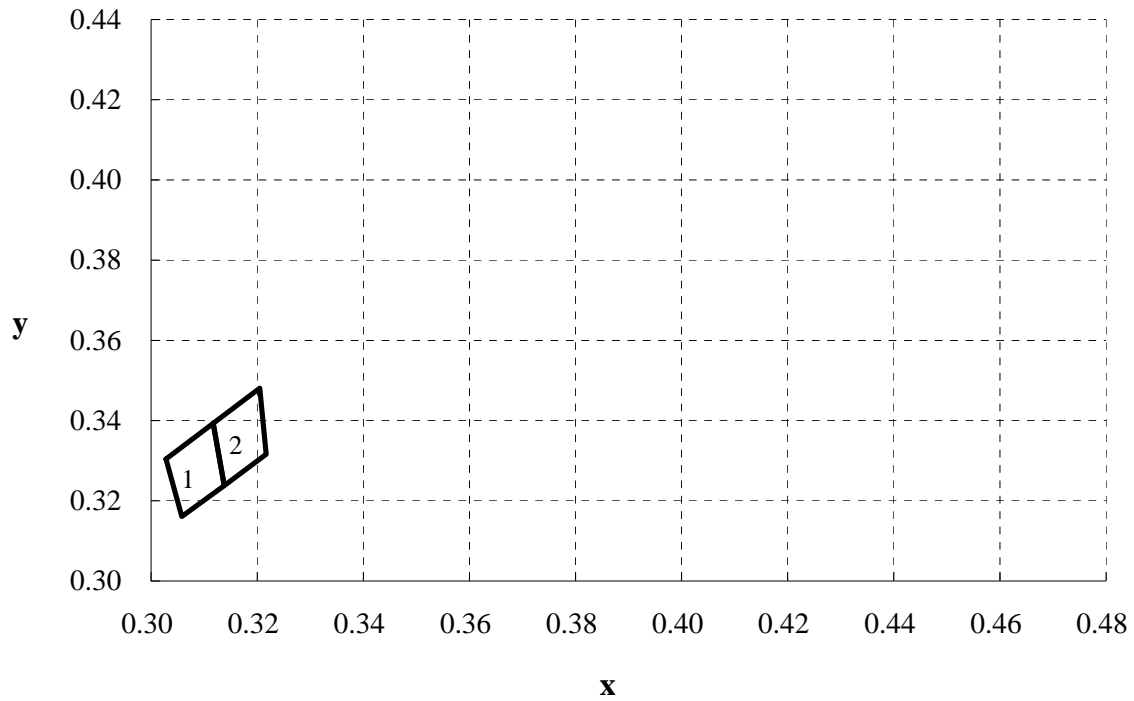

Chromaticity binning

GW5D****M**

GW5D**50M** CCT=5000K Chromaticity binning

GW5D*A50M** (IF=400mA, Tc=25°C)

GW5D*C50M** (IF=700mA, Tc=25°C)

Rank	Point 1		Point 2		Point 3		Point 4	
	x	y	x	y	x	y	x	y
1	0.3376	0.3616	0.3369	0.3431	0.3446	0.3493	0.3464	0.3688
2	0.3464	0.3688	0.3446	0.3493	0.3524	0.3555	0.3551	0.3760

Chromaticity Diagram

Tolerance x,y ±0.005

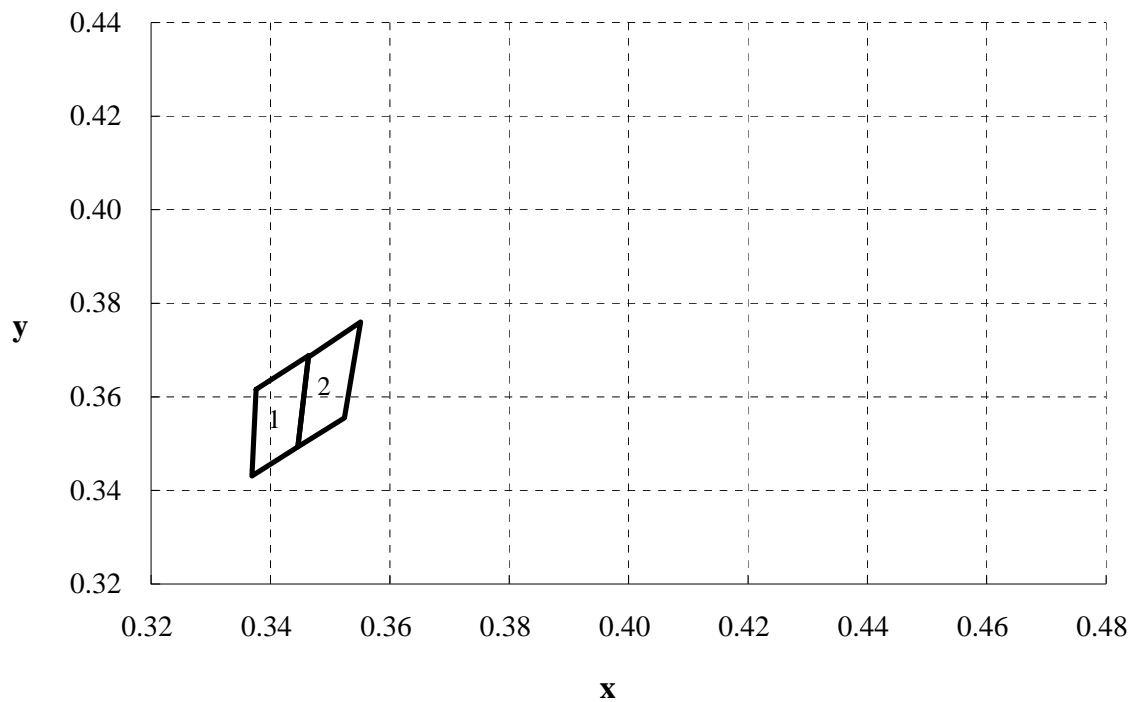

Chromaticity binning

GW5D****M**

GW5D**40M** CCT=4000K Chromaticity binning

GW5D*A40M** (IF=400mA, Tc=25°C)

GW5D*C40M** (IF=700mA, Tc=25°C)

Rank	Point 1		Point 2		Point 3		Point 4	
	x	y	x	y	x	y	x	y
1	0.3762	0.3890	0.3718	0.3700	0.3775	0.3724	0.3826	0.3919
2	0.3826	0.3919	0.3775	0.3724	0.3837	0.3750	0.3895	0.3950

Chromaticity Diagram

Tolerance x,y ±0.005

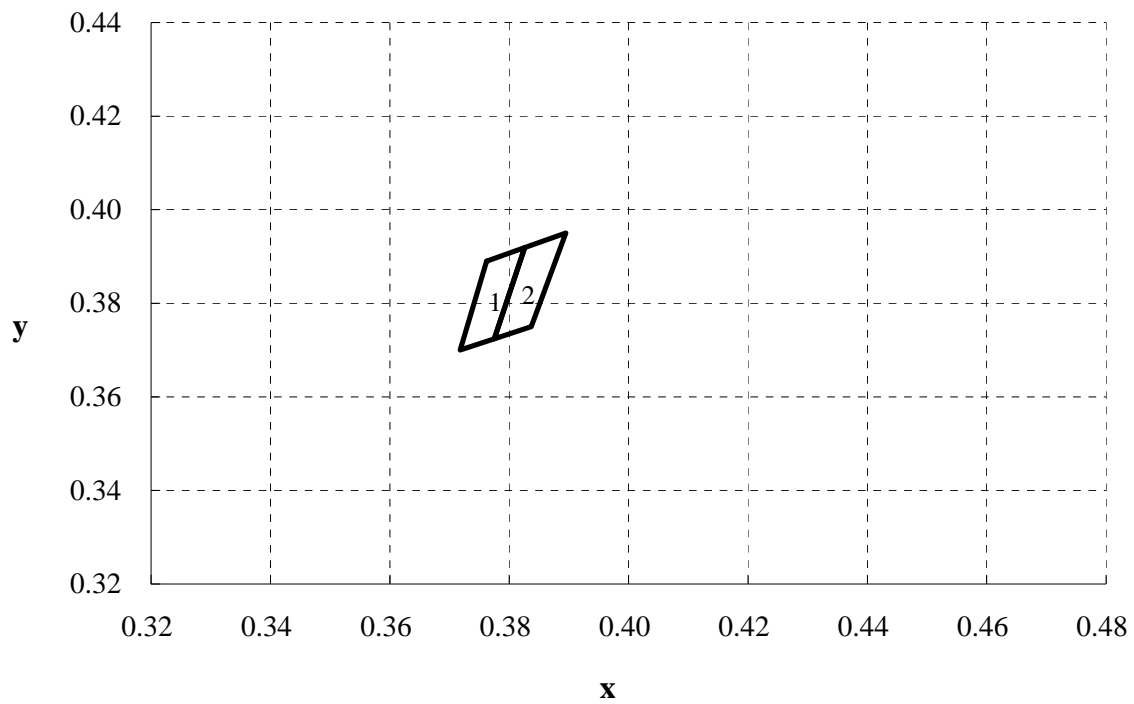

Chromaticity binning

GW5D****M**

GW5D**35M** CCT=3500K Chromaticity binning

GW5D*A35M** (IF=400mA, Tc=25°C)

GW5D*C35M** (IF=700mA, Tc=25°C)

Rank	Point 1		Point 2		Point 3		Point 4	
	x	y	x	y	x	y	x	y
1	0.4041	0.4000	0.3988	0.3850	0.4054	0.3850	0.4112	0.4000
2	0.4112	0.4000	0.4054	0.3850	0.4124	0.3850	0.4186	0.4000

Chromaticity Diagram

Tolerance x,y ±0.005

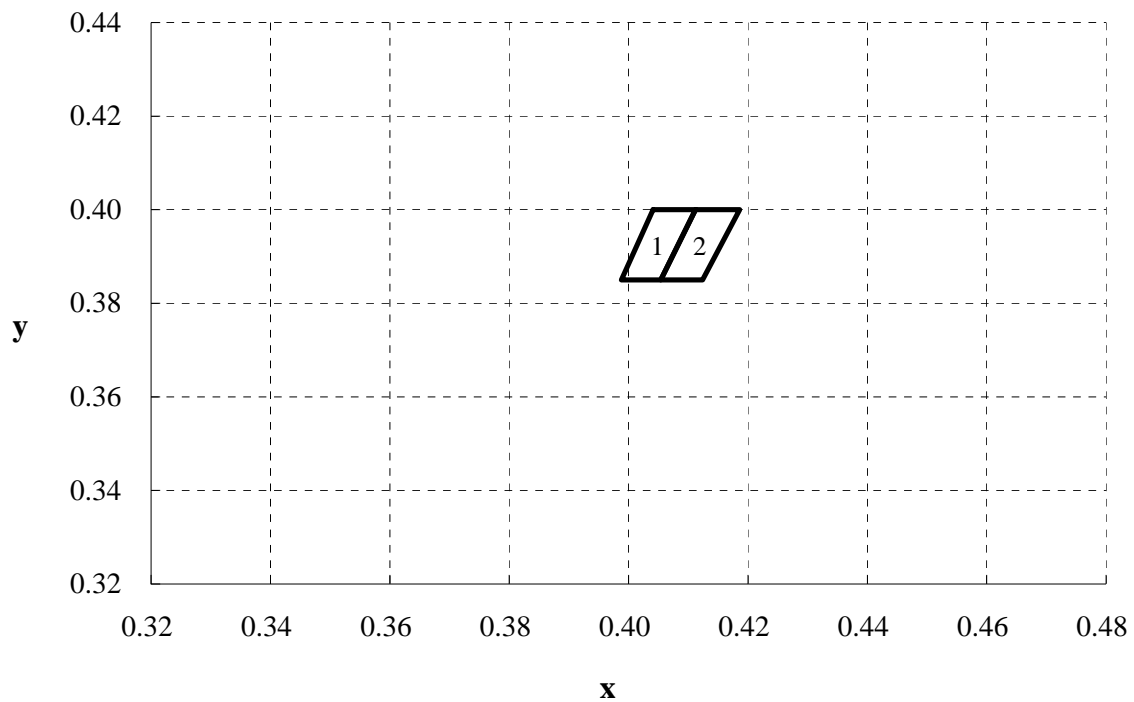

Chromaticity binning

GW5D****M**

GW5D**30M** CCT=3000K Chromaticity binning

GW5D*A30M** (IF=400mA, Tc=25°C)

GW5D*C30M** (IF=700mA, Tc=25°C)

Rank	Point 1		Point 2		Point 3		Point 4	
	x	y	x	y	x	y	x	y
1	0.4310	0.4100	0.4243	0.3950	0.4311	0.3950	0.4383	0.4100
2	0.4383	0.4100	0.4311	0.3950	0.4384	0.3950	0.4460	0.4100

Chromaticity Diagram

Tolerance x,y ±0.005

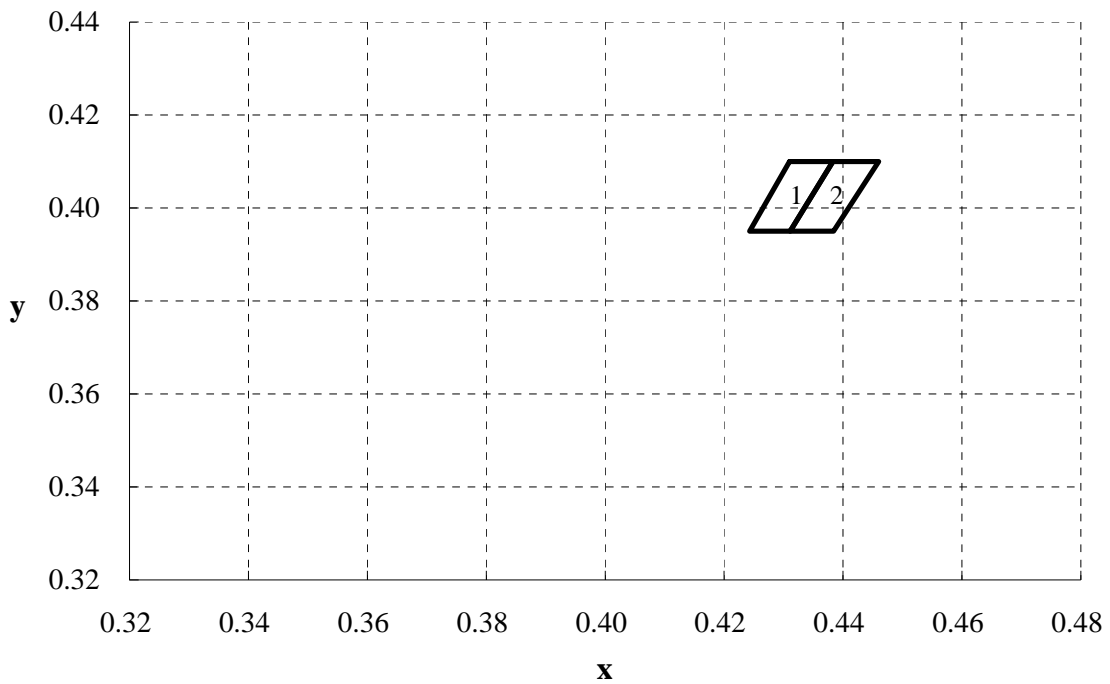

Chromaticity binning

GW5D****M**

GW5D**27M** CCT=2700K Chromaticity binning

GW5D*A27M** (IF=400mA, Tc=25°C)

GW5D*C27M** (IF=700mA, Tc=25°C)

Rank	Point 1		Point 2		Point 3		Point 4	
	x	y	x	y	x	y	x	y
1	0.4606	0.4250	0.4526	0.4100	0.4595	0.4100	0.4679	0.4250
2	0.4679	0.4250	0.4595	0.4100	0.4669	0.4100	0.4756	0.4250

Chromaticity Diagram

Tolerance x,y ±0.005

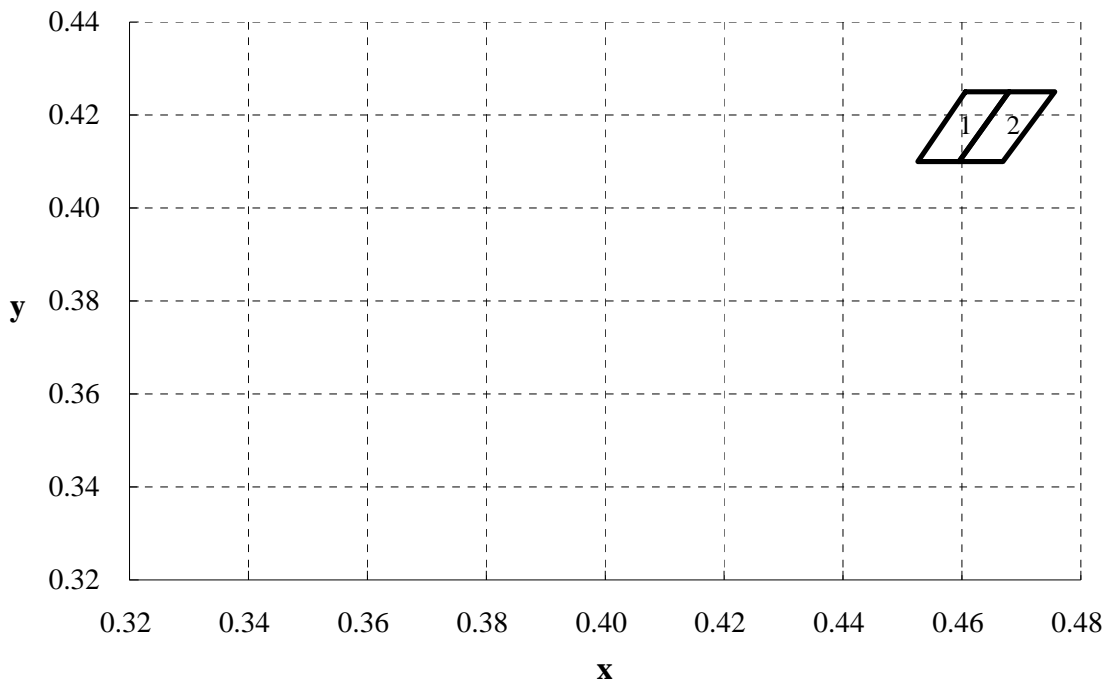

Emitting spectrum & Color rendering index

GW5D****M**

GW5DL*65M** CCT=6500K Emission spectrum

Emitting Spectrum

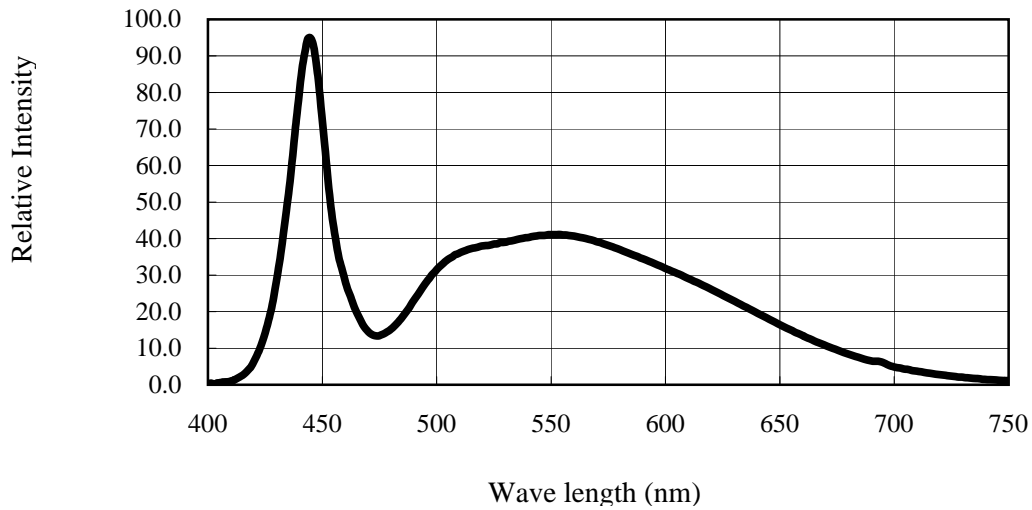

Color rendering index

Ra	R1	R2	R3	R4	R5	R6	R7	R8	R9	R10	R11	R12	R13	R14	R15
80	79	81	83	81	81	76	84	72	9	56	82	62	78	91	73

GW5DG*65M** CCT=6500K Emission spectrum

Emitting Spectrum

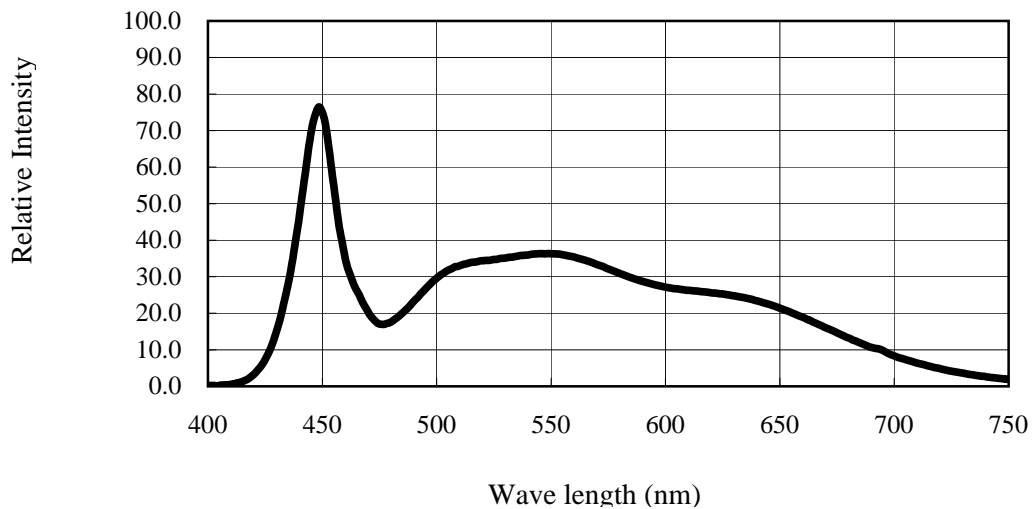

Ra	R1	R2	R3	R4	R5	R6	R7	R8	R9	R10	R11	R12	R13	R14	R15
88	87	88	88	89	88	83	92	87	57	72	88	65	87	93	86

Emitting spectrum & Color rendering index
 GW5D****M**

GW5DL*50M CCT=5000K Emission spectrum**

Emitting Spectrum

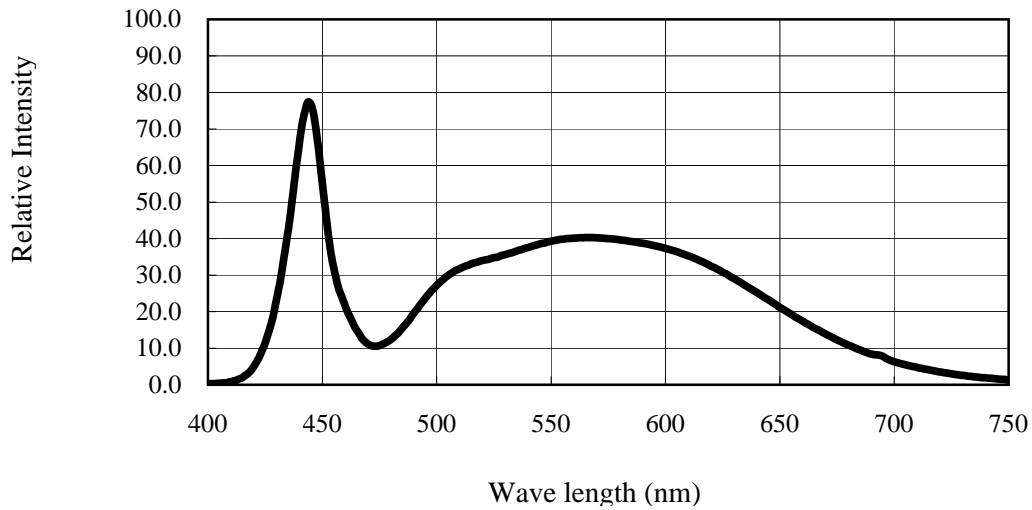

Color rendering index

Ra	R1	R2	R3	R4	R5	R6	R7	R8	R9	R10	R11	R12	R13	R14	R15
82	82	84	86	83	83	79	84	72	20	63	85	67	81	92	77

GW5DG*50M CCT=5000K Emission spectrum**

Emitting Spectrum

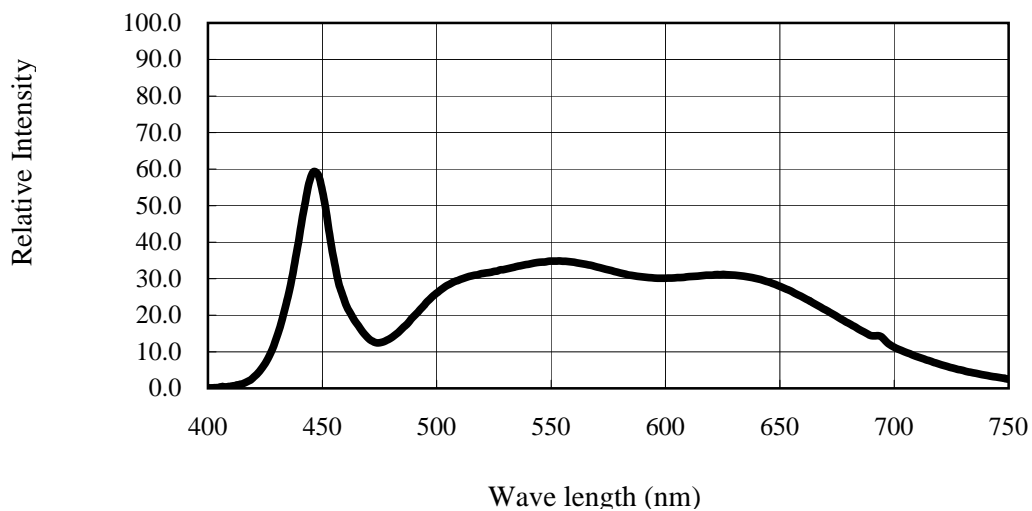

Ra	R1	R2	R3	R4	R5	R6	R7	R8	R9	R10	R11	R12	R13	R14	R15
90	92	90	87	90	91	86	90	90	74	77	91	74	91	93	92

Emitting spectrum & Color rendering index

GW5D****M**

GW5DL*40M** CCT=4000K Emission spectrum

Emitting Spectrum

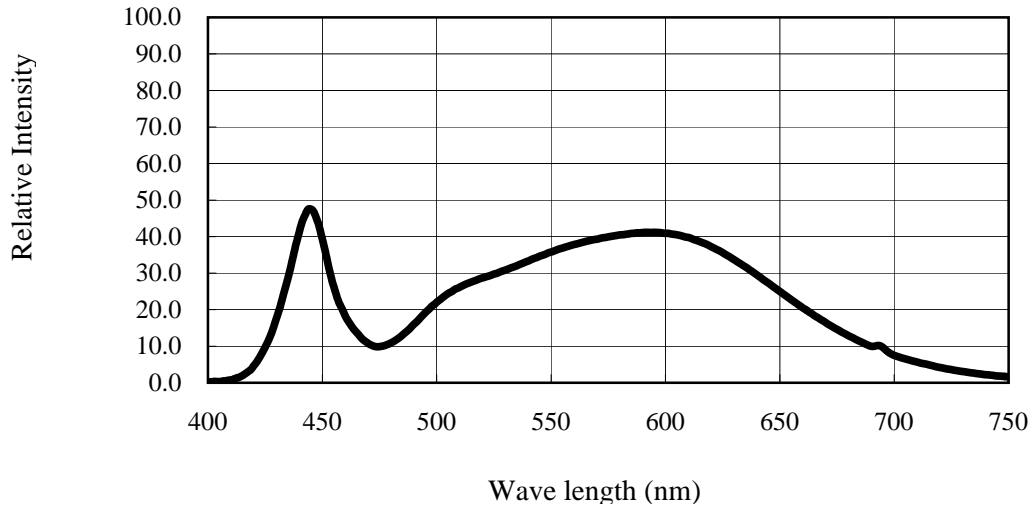

Color rendering index

Ra	R1	R2	R3	R4	R5	R6	R7	R8	R9	R10	R11	R12	R13	R14	R15
84	83	87	91	84	83	83	87	71	23	70	84	68	83	95	78

GW5DG*40M** CCT=4000K Emission spectrum

Emitting Spectrum

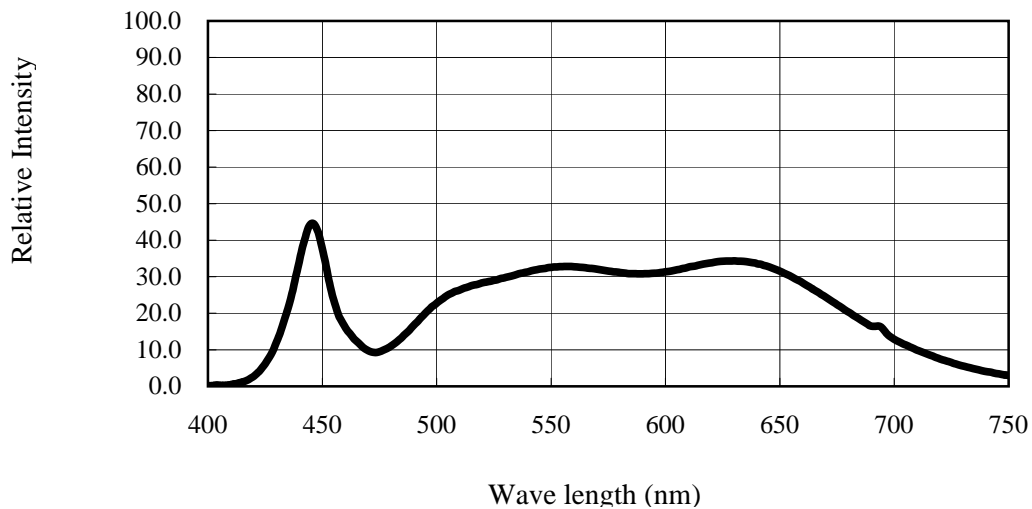

Ra	R1	R2	R3	R4	R5	R6	R7	R8	R9	R10	R11	R12	R13	R14	R15
91	94	91	87	90	93	88	91	92	84	79	91	76	93	92	94

Emitting spectrum & Color rendering index
 GW5D****M**

GW5DM*35M CCT=3500K Emission spectrum**

Emitting Spectrum

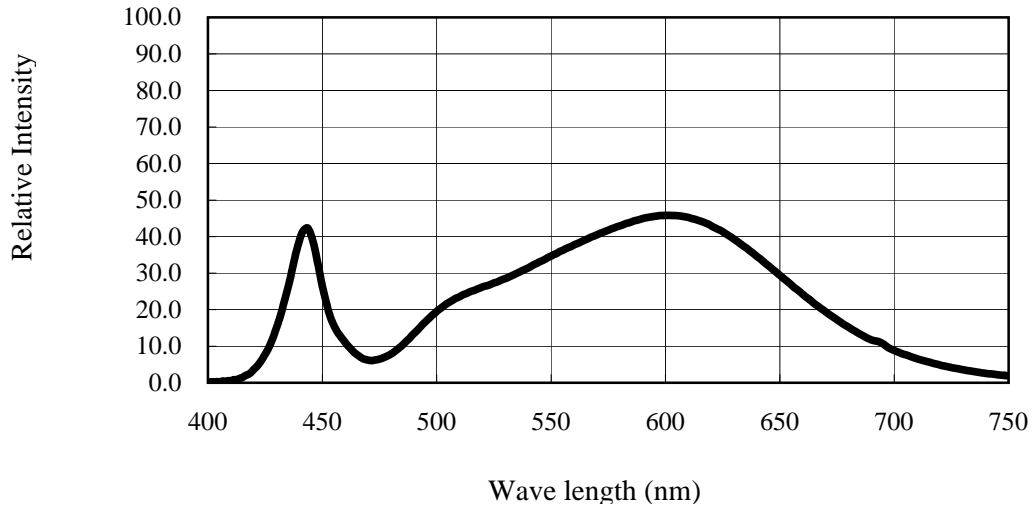

Color rendering index

Ra	R1	R2	R3	R4	R5	R6	R7	R8	R9	R10	R11	R12	R13	R14	R15
83	81	87	92	83	82	83	85	67	18	70	83	69	82	95	76

GW5DG*35M CCT=3500K Emission spectrum**

Emitting Spectrum

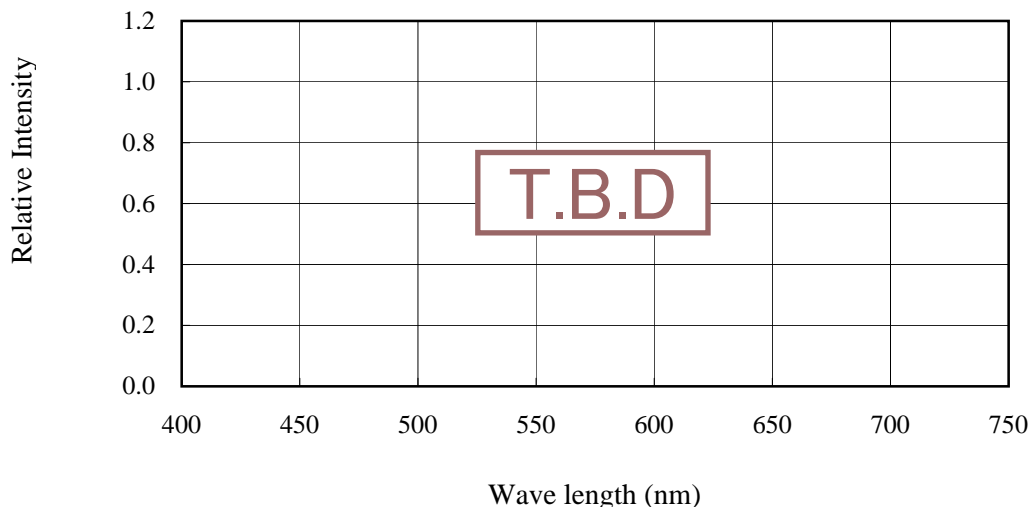

Ra	R1	R2	R3	R4	R5	R6	R7	R8	R9	R10	R11	R12	R13	R14	R15
-	-	-	-	-	-	-	-	-	-	-	-	-	-	-	-

Emitting spectrum & Color rendering index

GW5D****M**

GW5DM*30M** CCT=3000K Emission spectrum

Emitting Spectrum

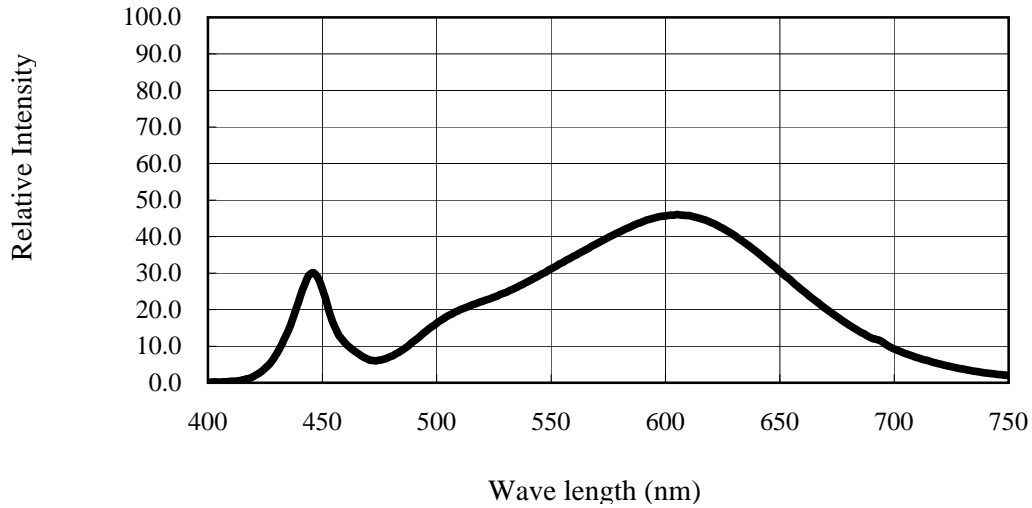

Color rendering index

Ra	R1	R2	R3	R4	R5	R6	R7	R8	R9	R10	R11	R12	R13	R14	R15
83	81	89	95	82	81	85	85	64	17	74	81	71	82	97	76

GW5DG*30M** CCT=3000K Emission spectrum

Emitting Spectrum

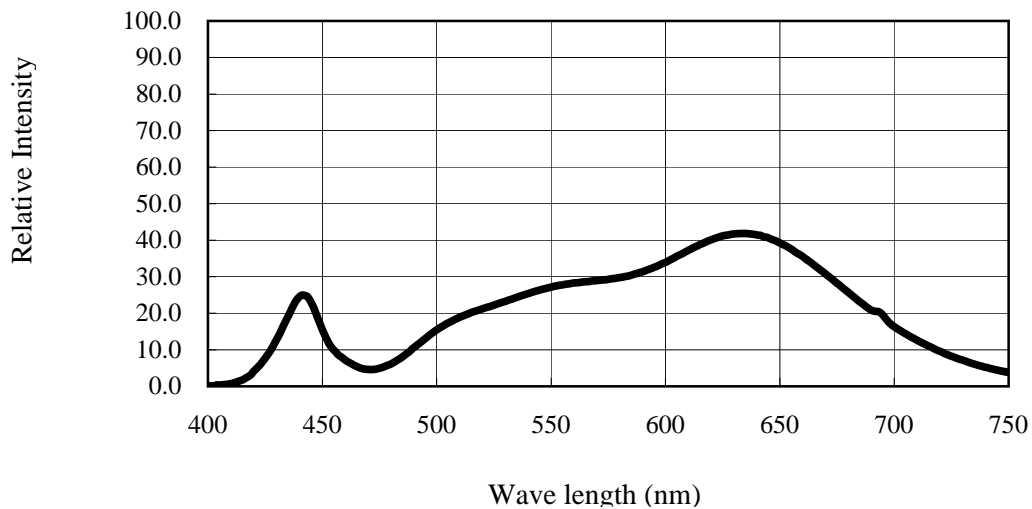

Ra	R1	R2	R3	R4	R5	R6	R7	R8	R9	R10	R11	R12	R13	R14	R15
93	97	94	89	91	95	92	91	92	87	86	92	84	96	93	95

Emitting spectrum & Color rendering index

GW5D****M**

GW5DM*27M** CCT=2700K Emission spectrum

Emitting Spectrum

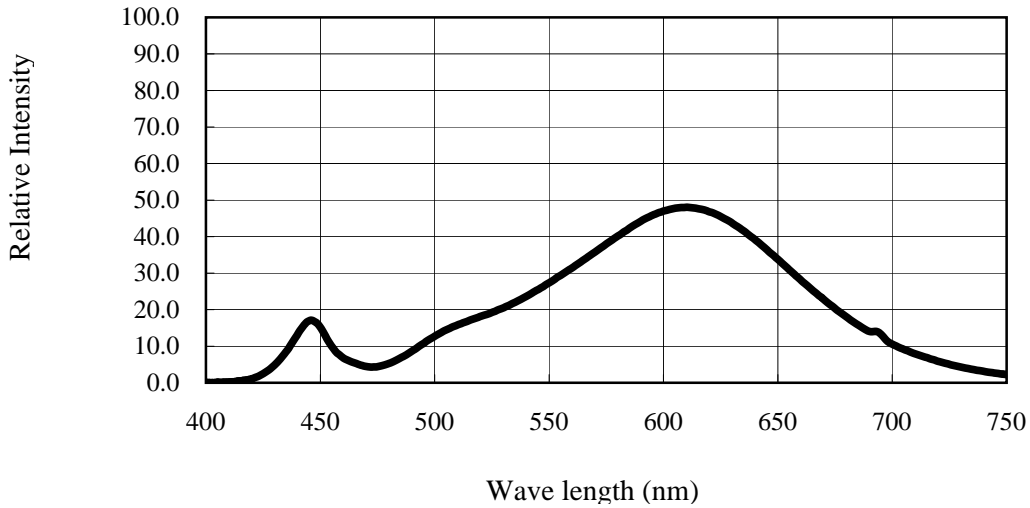

Color rendering index

Ra	R1	R2	R3	R4	R5	R6	R7	R8	R9	R10	R11	R12	R13	R14	R15
82	80	89	97	80	79	86	84	60	13	75	79	71	81	98	73

GW5DG*27M** CCT=2700K Emission spectrum

Emitting Spectrum

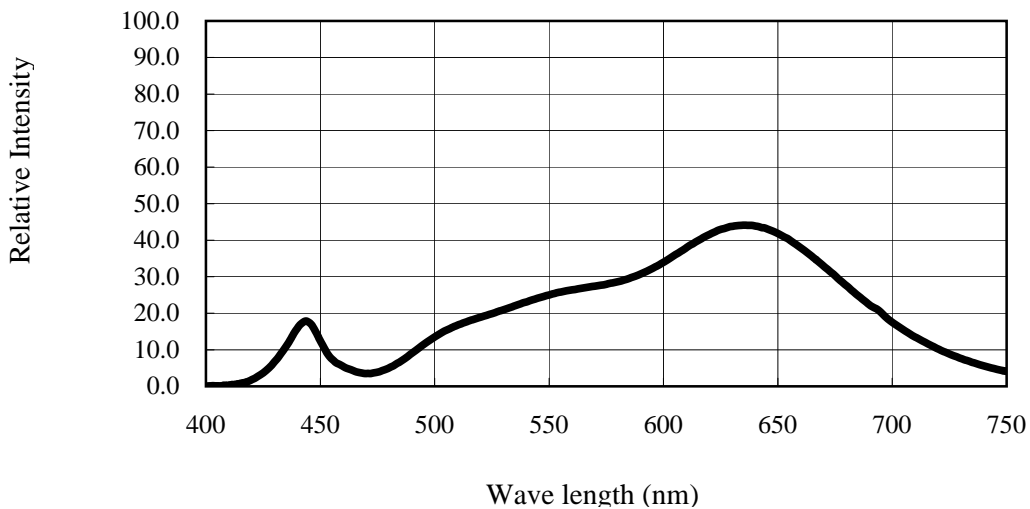

Ra	R1	R2	R3	R4	R5	R6	R7	R8	R9	R10	R11	R12	R13	R14	R15
94	98	95	91	93	96	94	94	94	86	88	93	86	97	94	96

Temperature characteristics

GW5D***M**

1. For all GW5D*C***M** products family

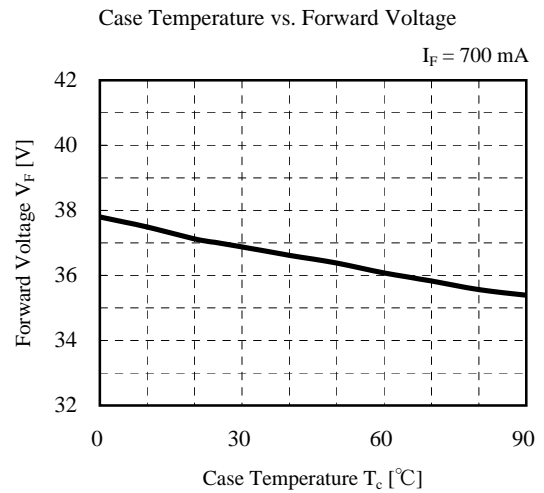
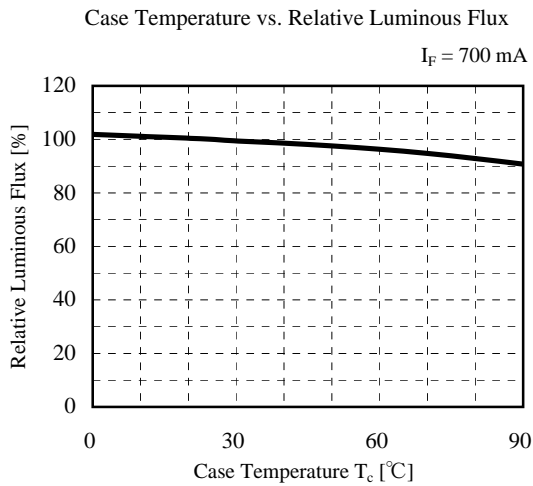

2. For all GW5D*A***M** products family

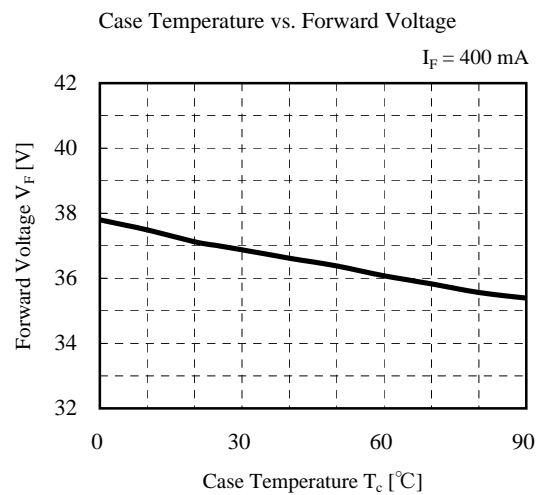
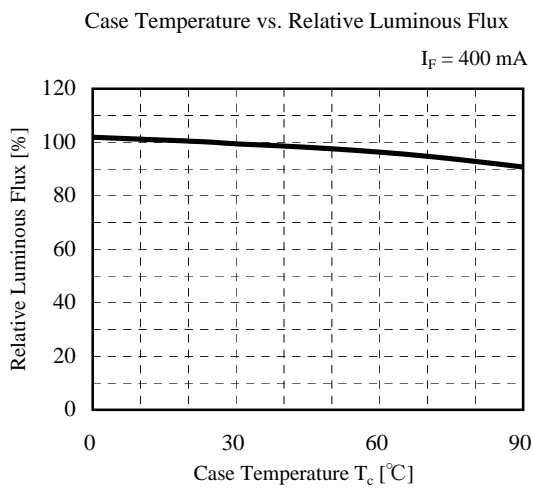

Derating curves

GW5D***M**

Derating Curves characteristics

1. For all GW5D*C**M** products family

<Fig.1> Forward Current Derating Curve

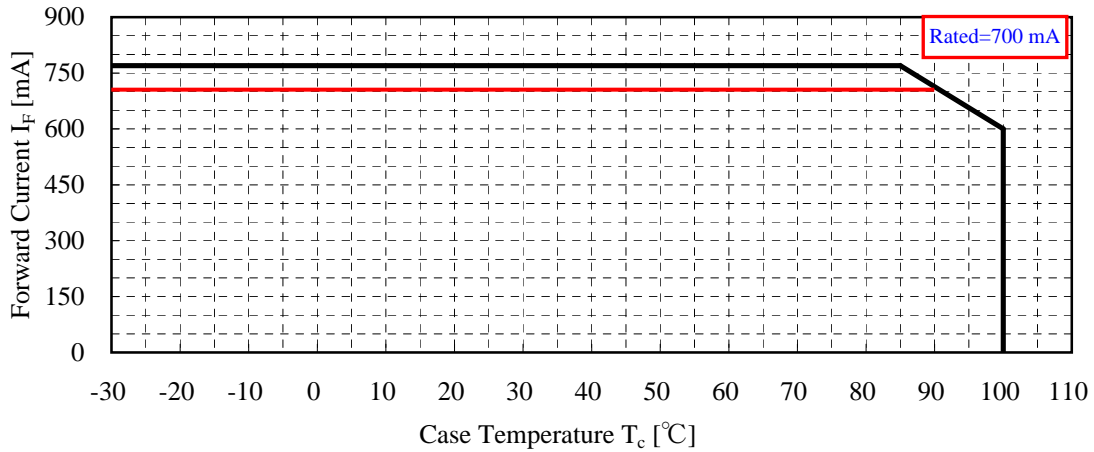

To keep T_c (Case-temperature) lower than the rating enough heat-radiation performance needs to be secured by using an adequate heat sink.

2. For all GW5D*A**M** products family

<Fig.2> Forward Current Derating Curve

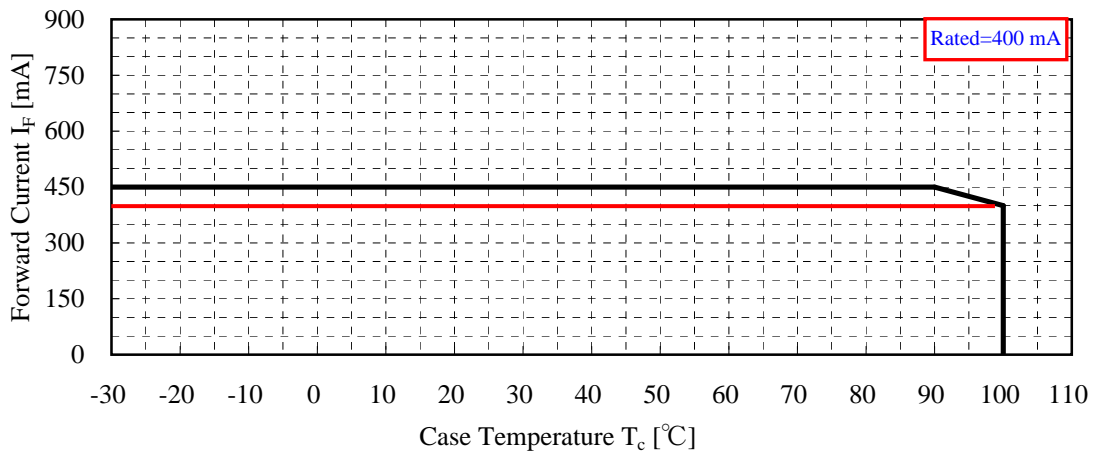

To keep T_c (Case-temperature) lower than the rating enough heat-radiation performance needs to be secured by using an adequate heat sink.

Electrical characteristics

GW5D***M**

Electrical Characteristics

1. For all GW5D*C**M** products family

<Fig.3> Forward Current vs. Relative Luminous Flux

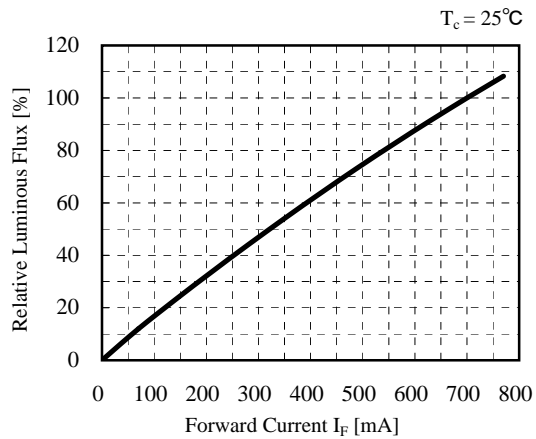

<Fig.4> Forward Voltage vs. Forward Current

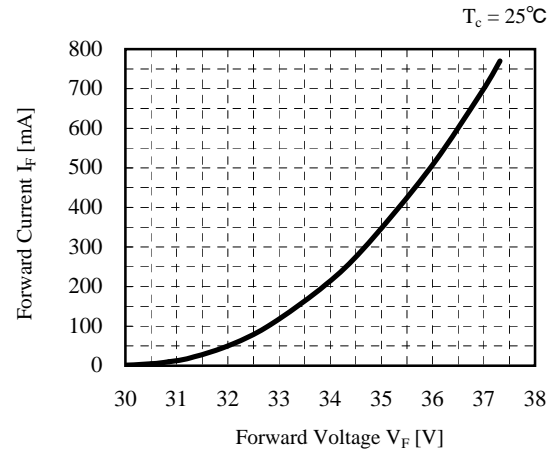

2. For all GW5D*A**M** products family

<Fig.5> Forward Current vs. Relative Luminous Flux

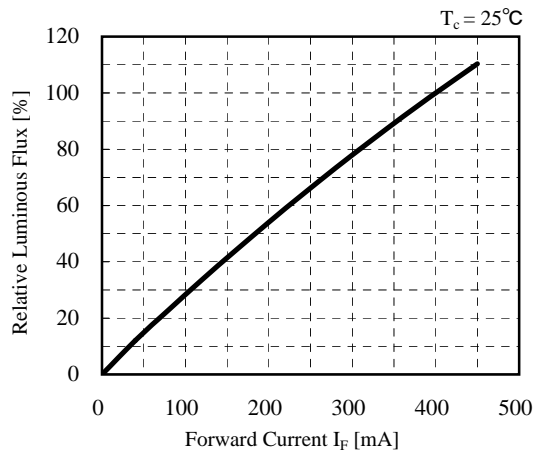

<Fig.6> Forward Voltage vs. Forward Current

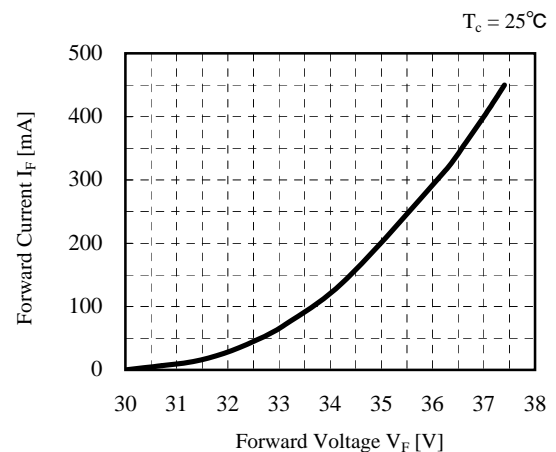

Reliability test data

GW5D****M**

Reliability test data at Tc=90°C

1. For all GW5D****M** products family

<Condition>

Operating condition : Tc=+90°C (Ta=+25°C), IF=770mA

Measurement condition : Tc=+25°C, IF=770mA

Sample quantity : 2 pieces

<Fig.7> Relative Forward Voltage

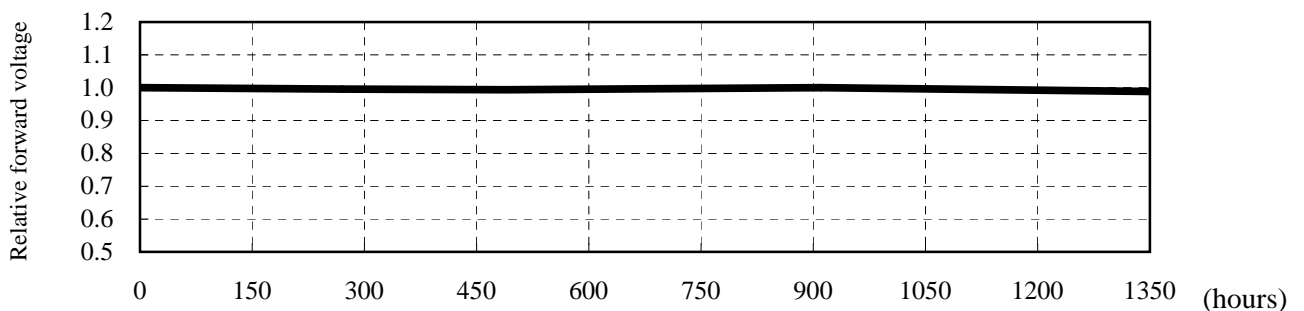

<Fig.8> Relative Luminous Intensity

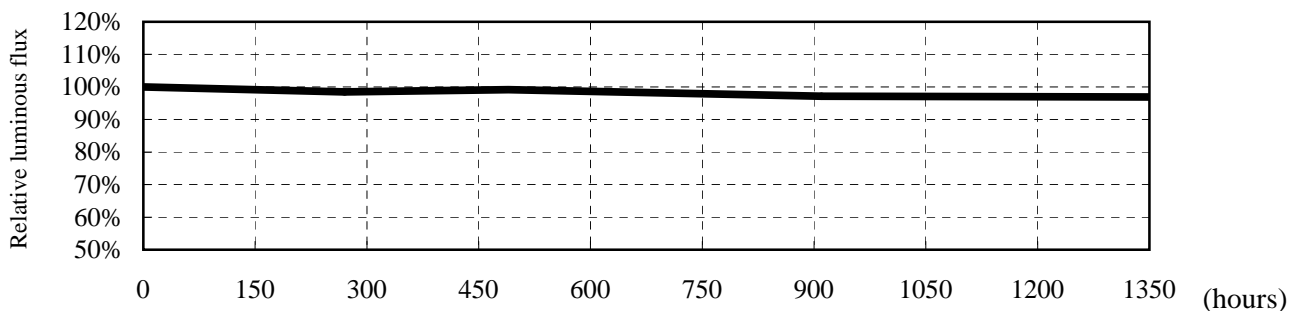

<Fig.9> ΔCIE_X Relative Chromaticity

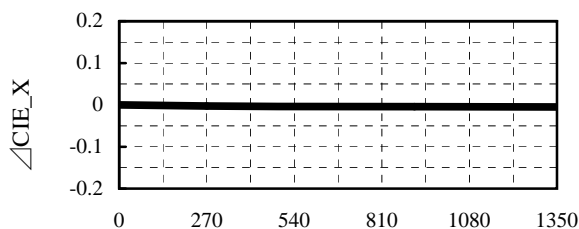

<Fig.10> ΔCIE_Y Relative Chromaticity

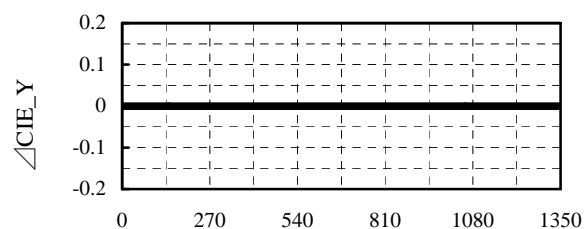

*These data shown here are for reference purpose only. (Not guaranteed data)

Flux distribution characteristics

GW5D****M**

Flux Distribution Characteristics
 (for all GW5D****M** products family)

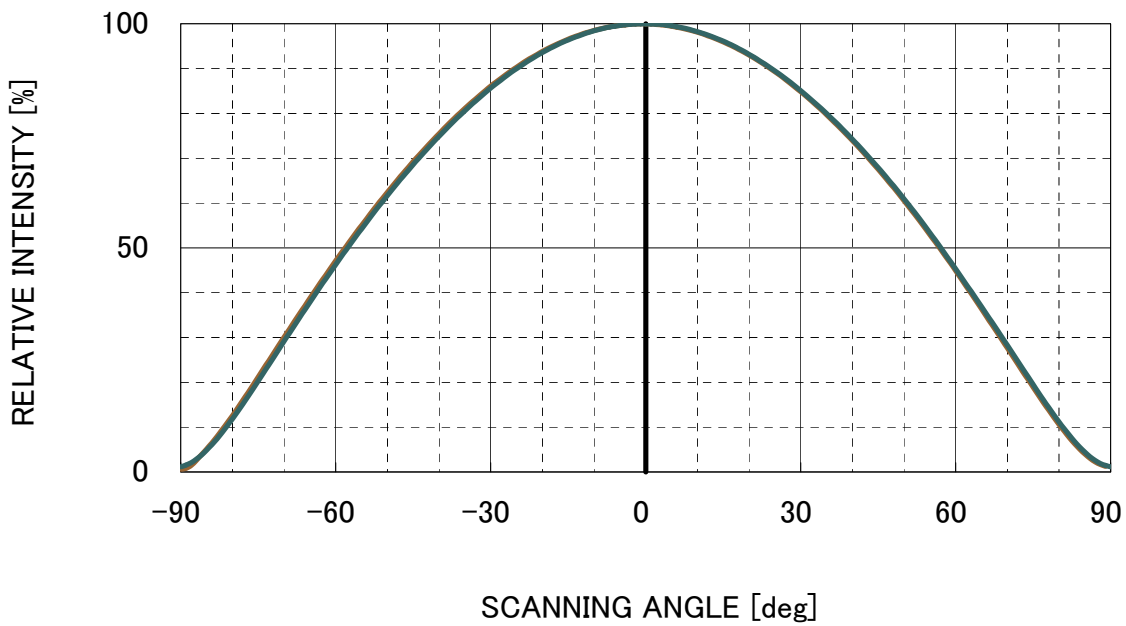
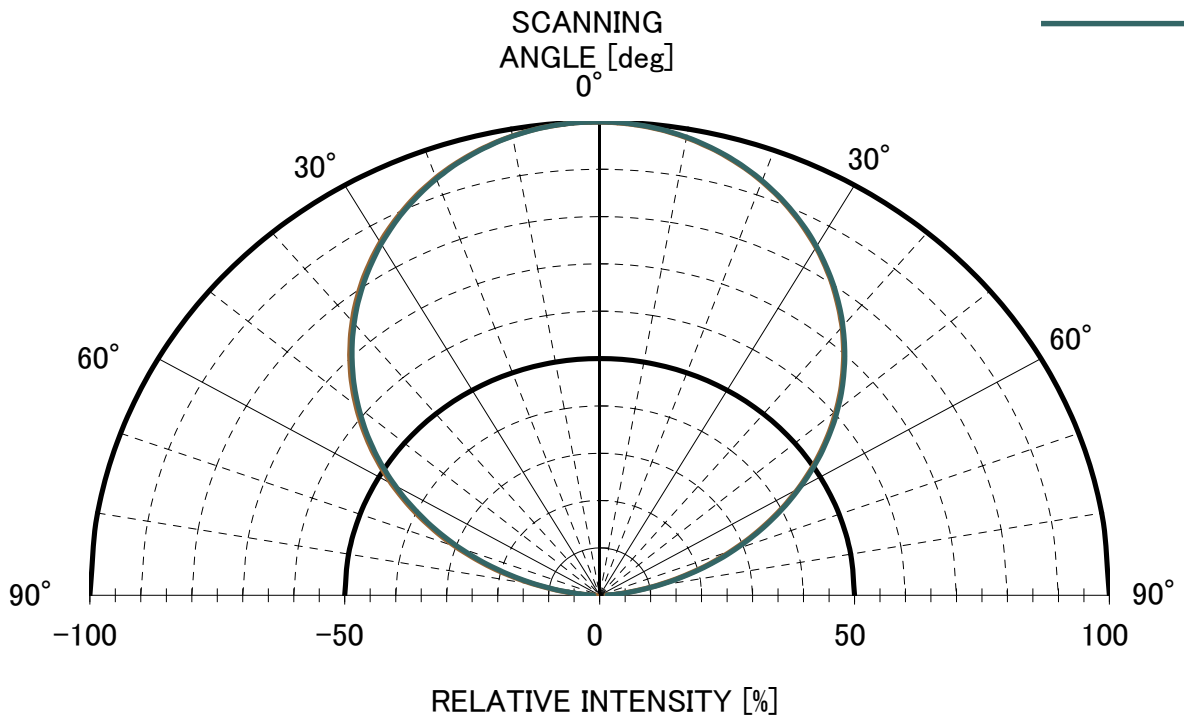
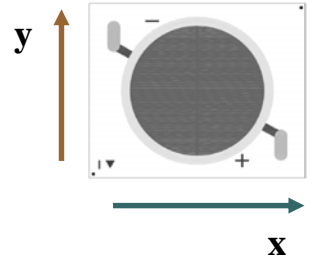

Application Note

Appearance

GW5D***M**

Appearance

GW5D*C*M** has 12 series and 14 parallel, totally 168 LED dice on board. Furthermore, protection circuit are also on board due to protect LED dies from the damage of reverse bias. Below descriptions are outer size & circuit pattern.

<Fig.11> Outer size & circuit pattern

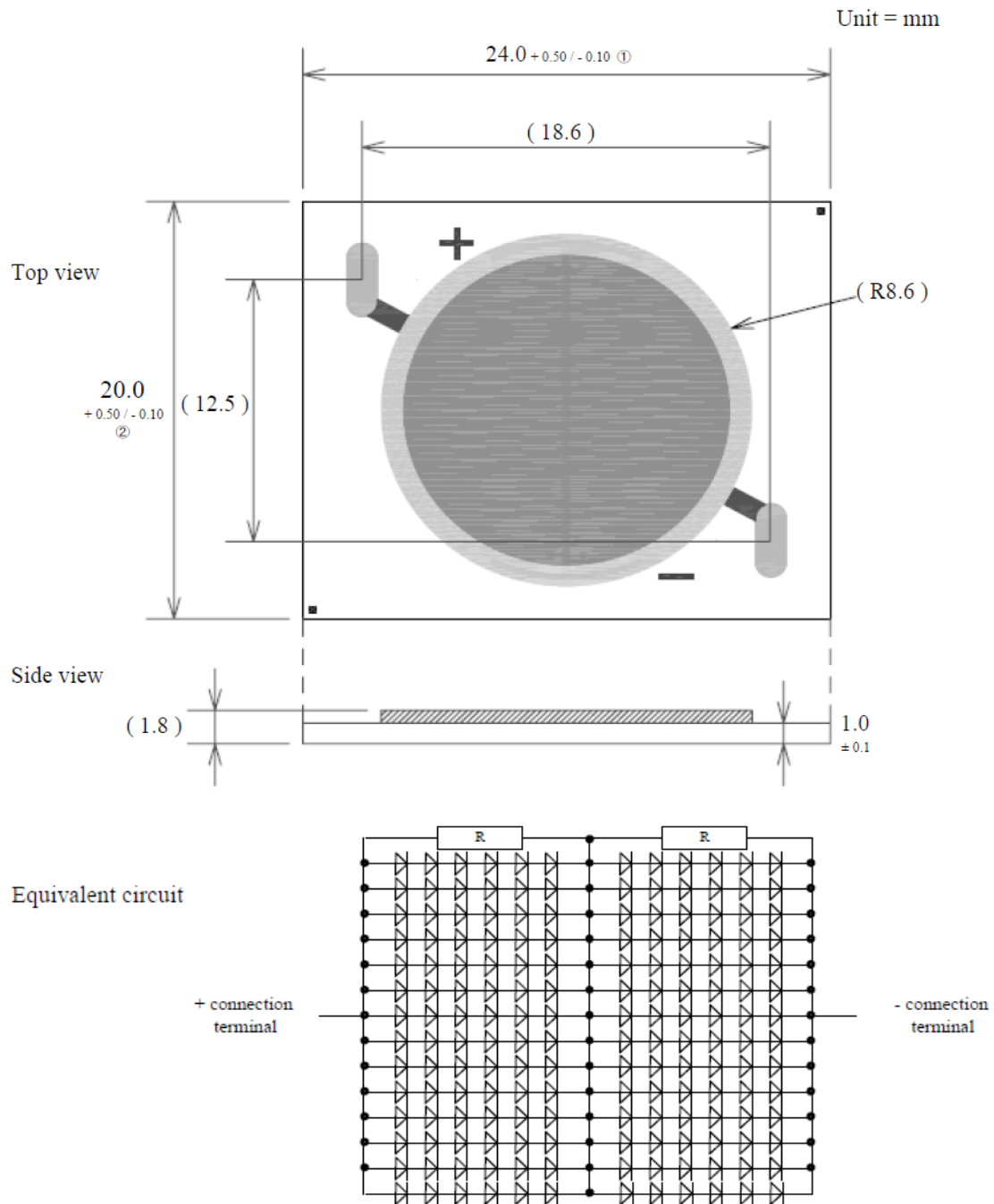

Appearance

GW5D***M**

Appearance

GW5D*A**M** has 12 series and 8 parallel, totally 96 LED dice on board. Furthermore, protection circuit are also on board due to protect LED dies from the damage of reverse bias. Below descriptions are outer size & circuit pattern.

<Fig.12> Outer size & circuit pattern

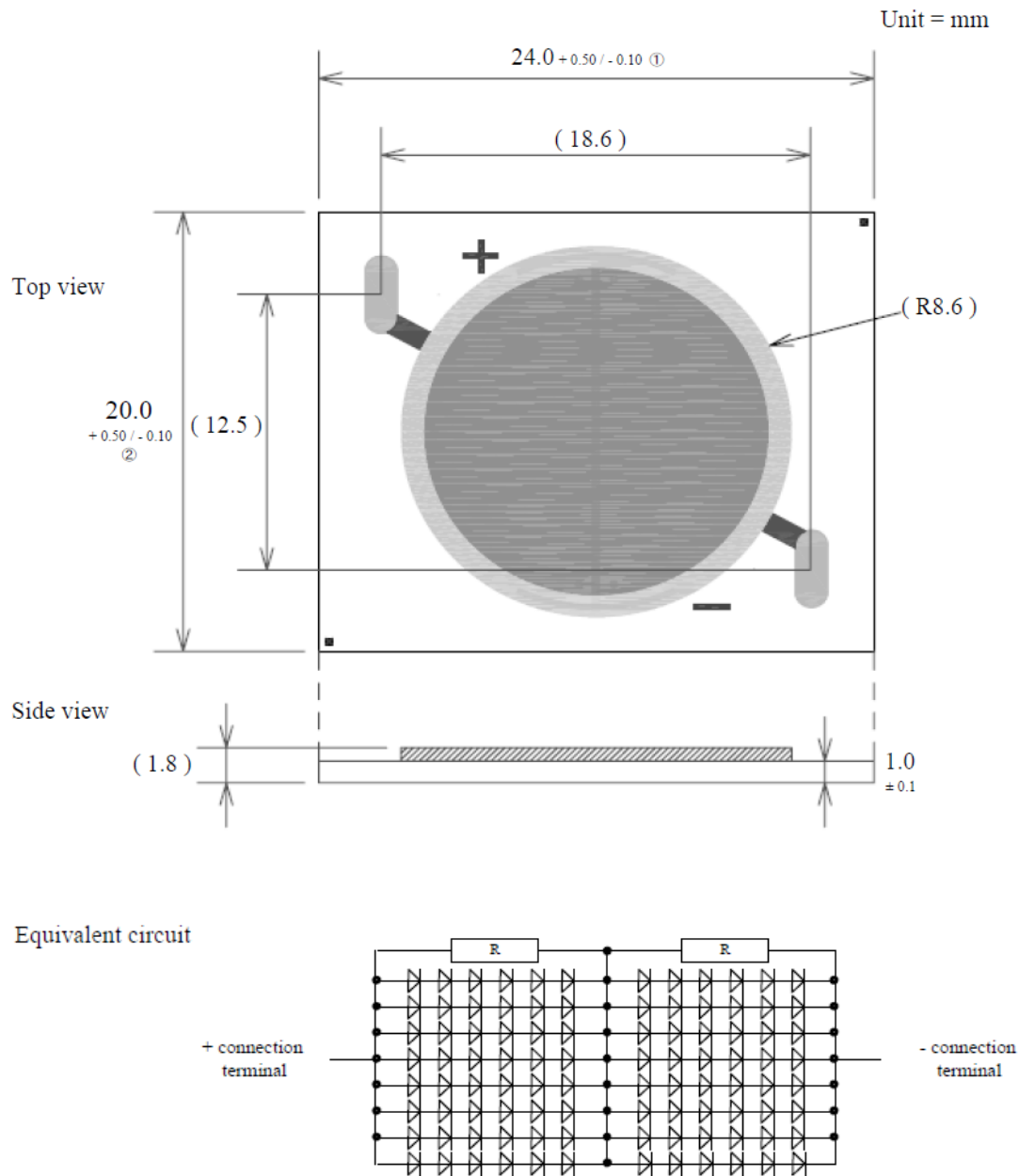

Protection circuit function

GW5D****M**

Function of protective resistance

1. General

In general, GaN based LED is thought that it is subject to reverse bias caused by condition of electric circuit or photovoltaic effect. To improve performance against reverse bias, GW5D****M** series has built in protective resistance. Below shows basic IF-V curve characteristics of GaN based LED and function of built-in protective resistance.

2. IF-V curve characteristics of LED

Fig.14 shows IF-V curve characteristics of typical GaN based blue LED.

In general, the direction from anode to cathode is called as “forward direction”, while that from cathode to anode is called as “reverse direction”.

Below shows IF-V curve characteristics for forward direction, reverse direction and circuit with protective resistance.

<2-1. IF-V curve characteristics for forward direction>

IF-V curve characteristics for forward direction shows little current flow due to higher resistance during low voltage (See area B in Fig.14). However, the more voltage goes up the more current flow when the voltage exceeds certain threshold point (See area A in Fig.14). For forward direction, current flow will increase accordingly as voltage is applied.

<2-2. IF-V curve characteristics for reverse direction>

For reverse direction, current is negligible even if 15V is applied in the case of reverse direction (see area C in Fig.14) Accumulated electric charges due to reverse bias may lead to break-down of PN junction as a result.

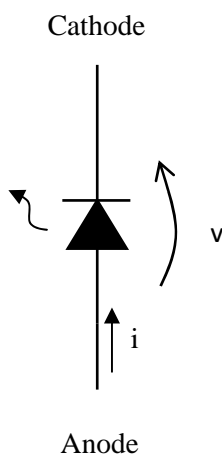

<Fig.13> Current/Voltage for forward direction

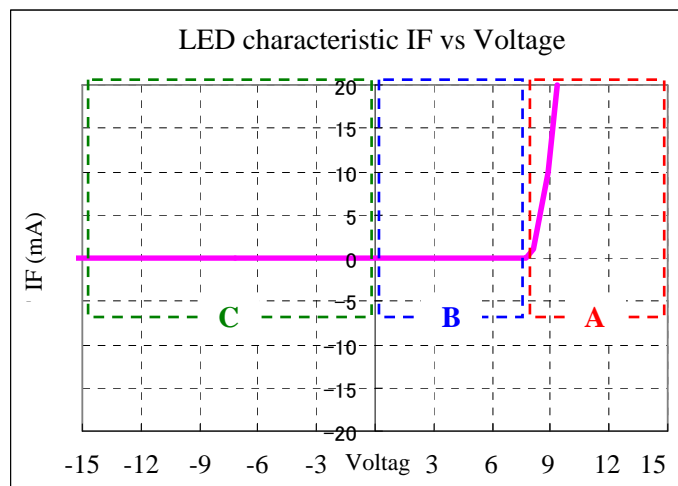

<Fig.14> IF-V characteristics of LED

Protection circuit function

GW5D****M**

<2-3. Protective Resistor Function>

Fig.16 shows IF-V curve characteristics for a LED with built-in protective resistor.

During low voltage in the case of forward direction with over threshold voltage, current goes through not resistor but LED.

On the other hand, current flow to protective resistor will become dominant in case reverse direction voltage is applied because reverse current of LED is negligible. 15V in case of reverse direction. So protection circuit has by-pass function for reverse bias.

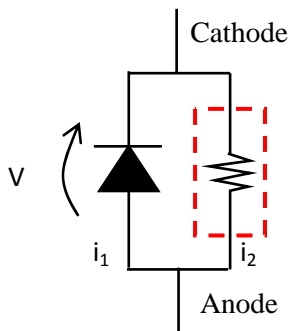

<Fig.15> Diagram for LED & protective resistor

LED+Protection circuit vs Voltage

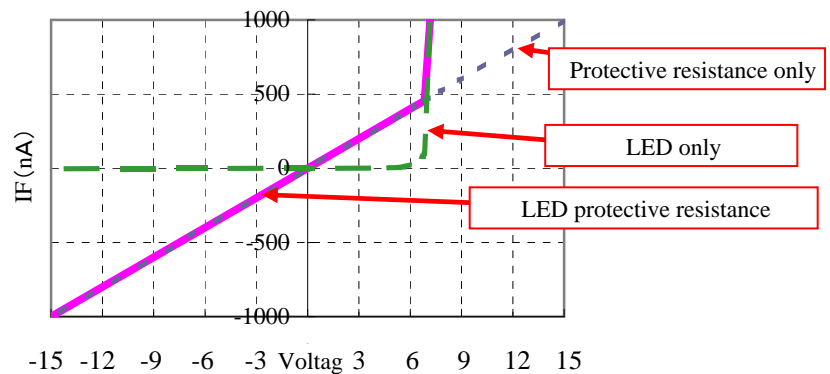

<Fig.16> IF-V Characteristics for LED & protective resistor

<2-4. Current flow to protective resistor>

Mega-zenigata LED should be used in adequate forward current to bring out required luminouce performance. Expected range of current, Mega-zenigata LED is designed as a most all current drive through LED. Fig.17 shows approximate current to resistor by operation current as a reference value.

Input Current (mA)	Approx. current value (μA)	Input Current (mA)	Approx. current value (μA)
100	<1.0	500	<1.0
200	<1.0	600	<1.0
300	<1.0	650	<1.0
400	<1.0	700	<1.0
450	<1.0	770	<1.0

<Fig.17> Input Current vs. Current loaded in protective resistor

Current flow to protective resistor at over 100mA of input current is approx. 0.001mA ($1 \mu A$).

1/100,000 level of current flow in LED. Impact of protective resistor to power consumption will be negligible.

GW5D****M** series incorporates protection circuit for reverse direction, which is supposed to function against temporary reverse voltage. This protection circuit will not work for a product for which reverse voltage is loaded constantly.

Thermal resistance

GW5D****M**

1. General

Along with the improvement of luminous efficiency, LED is getting widely used these days for applications which require high output power such as LED lighting and backlight system for LCD TV. The more prevail, the more input power is required for LED and the more heat is generated dramatically. When LED device generates heat, it will cause degradation of luminous efficiency and life, which will result in difficulty in obtaining expected performance. It is essential, therefore, that optimum heat. Here is the explanation of resistance necessary for heat design and how the temperature goes up in the actual usage conditions.

2. Temperature definition

<2-1 Case temperature (Tc) >

The most important parameter for thermal resistance design of LED is temperature of light emitting element, PN junction of LED so called junction temperature (Tj). PN junction is light-emitting element. The higher the temperature of it becomes, the more electrical performance including life will be affected adversely. Therefore, it is critical to design effective heat release to make junction temperature become lower.

It is widely known to calculate junction temperature by VF measurement method or a calculation formula, case temperature (Tc) minus thermal resistance. VF measurement method is a way to estimate accurate junction temperature. However, it is not easy method because it requires special power supply. On the other hand, case temperature method is easy way as it requires measurement of case temperature only by thermo coupler or etc. However, estimated junction temperature will be less accurate and have a certain distribution. Therefore, actual junction temperature may exceed estimated junction temperature, which could give a negative impact to LED characteristics.

If you use Tj for designing actual heat release circuit, you have to set a optimum design margin taking two critical parameters, not only distribution of Tj-Tc but also tolerance of Tc measurement into account. Being different from release design by Tj only, Tj-Tc distribution has been taken into account for Sharp LED devices, including its distribution, which means that Tj-Tc distribution does not have to be considered. Sharp suggests that customers should set optimum design margin considering the other critical parameter, distribution of Tc measurement. See below Fig.18 for the relationship of Tj and Tc for LED devices.

<2-2 Relationship junction temperature (Tj) and Case temperature (Tc)>

Fig.18 shows the structure of Sharp LED devices, which consist of LED chip, die-attach resin, encapsulation resin and packaging.

<Fig.18> Structure

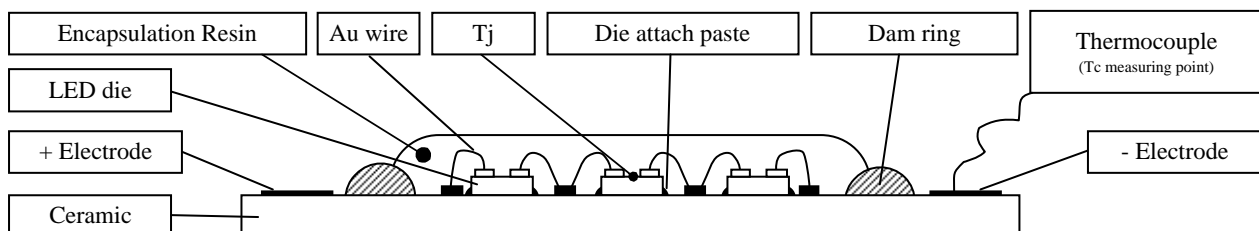

Thermal resistance

GW5D****M**

Heat release path from location of heat generation for LED chip to LED terminal is as follows;
 LED chip --> Die-attach resin (Resin for attach LED to substrate) --> Ceramic substrate --> LED terminal
 When Sharp LED is actually used, it is mounted on a print circuit board by soldering with heat sink when necessary. In this case, heat release path will be as follows;
 LED chip --> Die-attach resin --> Ceramic substrate --> LED terminal --> print circuit board --> heat sink
 Heat release path can be written by using a factor called thermal resistance as shown in the electrical diagram Fig.19.

<Fig.19> Thermal diagram with thermal resistance

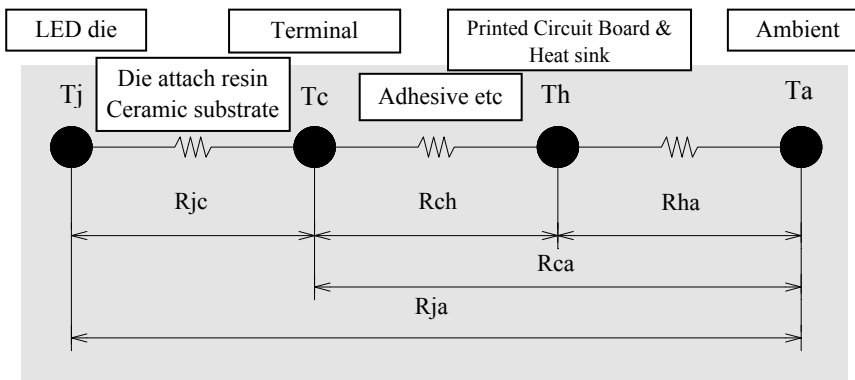

Tj: Junction Temperature
 Tc: Case Temperature
 Th: Heat sink temperature
 Ta: Ambient Temperature

Rjc: Thermal resistance between junction and case
 Rch: Thermal resistance between case and heat sink
 Rha: Thermal resistance between heat sink and ambient
 Rca: Thermal resistance between case and ambient
 Rja: Thermal resistance between junction and ambient

<Fig.20> Pattern diagram of temperature slope

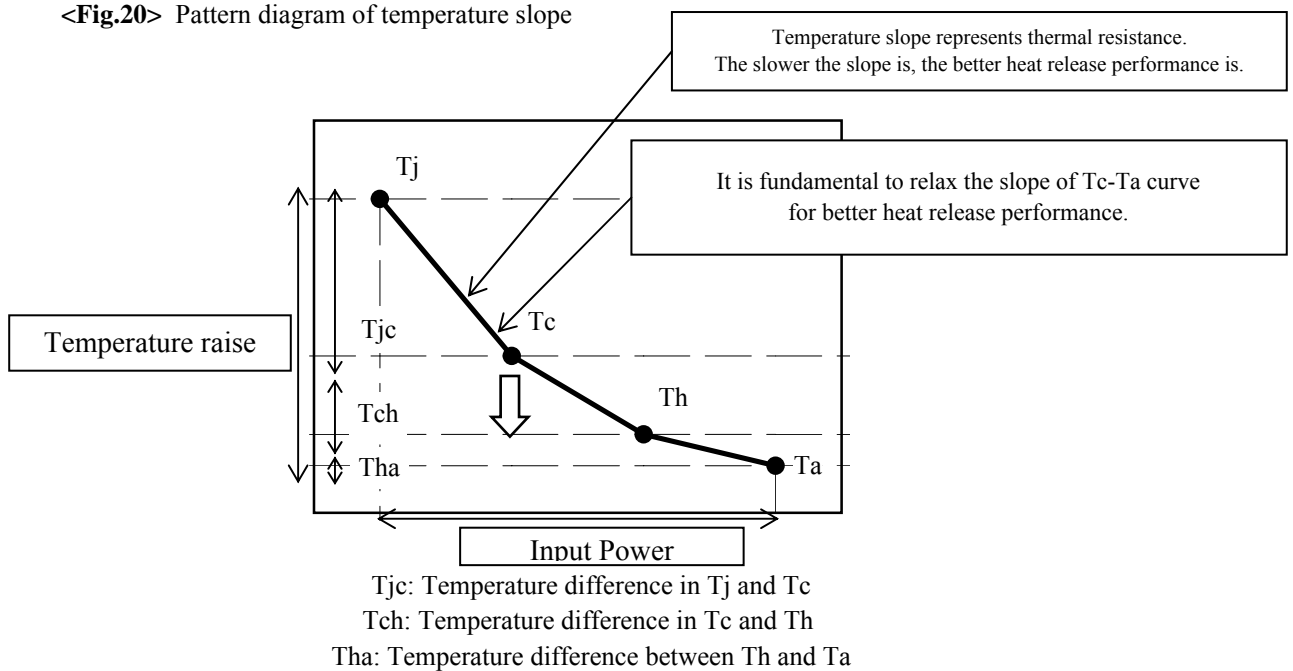

Thermal resistance

GW5D***M**

Factors such as Rja and Rca mean thermal resistance.

Unit of thermal resistance is [$^{\circ}\text{C}/\text{W}$], which means the relationship between input voltage and temperature increase.

For example, $10^{\circ}\text{C}/\text{W}$ means that temperature goes up 10°C per every input power 1W. Thermal resistance can be considered as the same with resistor [Ω] in electrical circuit. If X-axis means input power and Y-axis does temperature like Fig.20, thermal resistance means each point temperature slope. The slower the temperature slope is, the better heat release performance is. Therefore, the lower the thermal resistance is, the better heat release performance is.

Following formula with thermal resistance represents the relationship between Tj and Ta.

Formula

$$\begin{aligned} T_j &= T_a + \underline{R_{ha} \times W} + \underline{R_{ch} \times W} + \underline{R_{jc} \times W} \\ &= T_h + \underline{R_{ch} \times W} + \underline{R_{jc} \times W} \\ &= T_c + \underline{R_{jc} \times W} \end{aligned}$$

According to above formula, Tj can be calculated by Tc and input power.

Tc can be obtained by actual measurement by thermo coupler.

W can be measured by current and voltage of LED device.

Rjc is, as a reference value, approximately $2.0^{\circ}\text{C}/\text{W}$ (without any adhesive) for GW5D*C**M** series and approximately $3.0^{\circ}\text{C}/\text{W}$ (without any adhesive) for GW5D*A**M** series.

As you can see, lowering Tj has the same meaning of lowering Tc.

See page 29~30 for an example of measurement method and thermal resistance design in specific application.

Heat design

GW5D****M**

1. Tc measurement point

<1-1: How to measure case temperature>

Tc in this application note is measured by thermo coupler attached to the point mentioned in Fig.21.

Soldering is recommended to attach thermometer to this point.

<Fig.21> Recommended land pattern and Tc measurement point

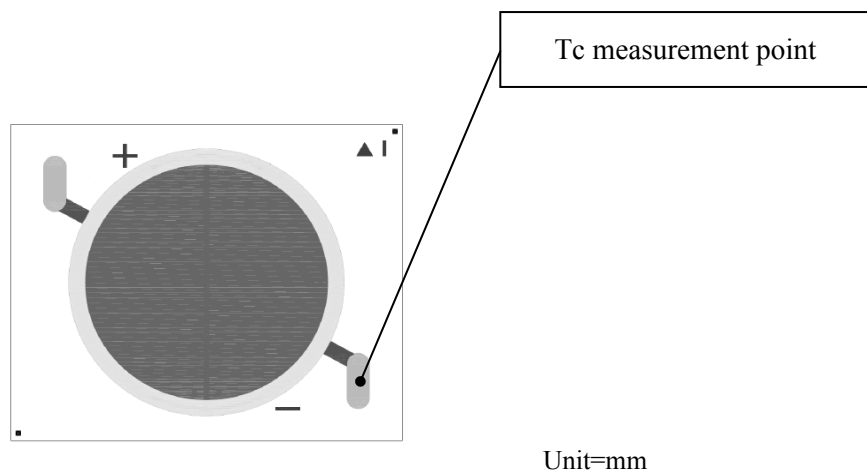

2. Device temperature

Tc must be within derating curve when operating. To keep Tc within derating curve, two options are available.

- option #1. Lower Rca (Terminal - Thermal resistance from case to atmosphere)
- option #2. Lower W (Input Power)

Priority should be option #1 because output would be lower for option #2.

Heat design

GW5D****M**

6. Design flow chart

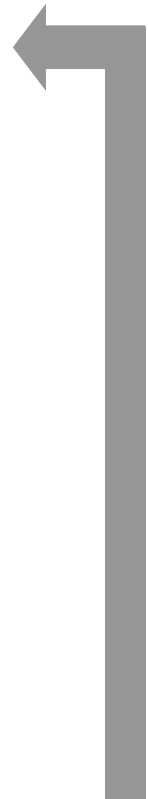
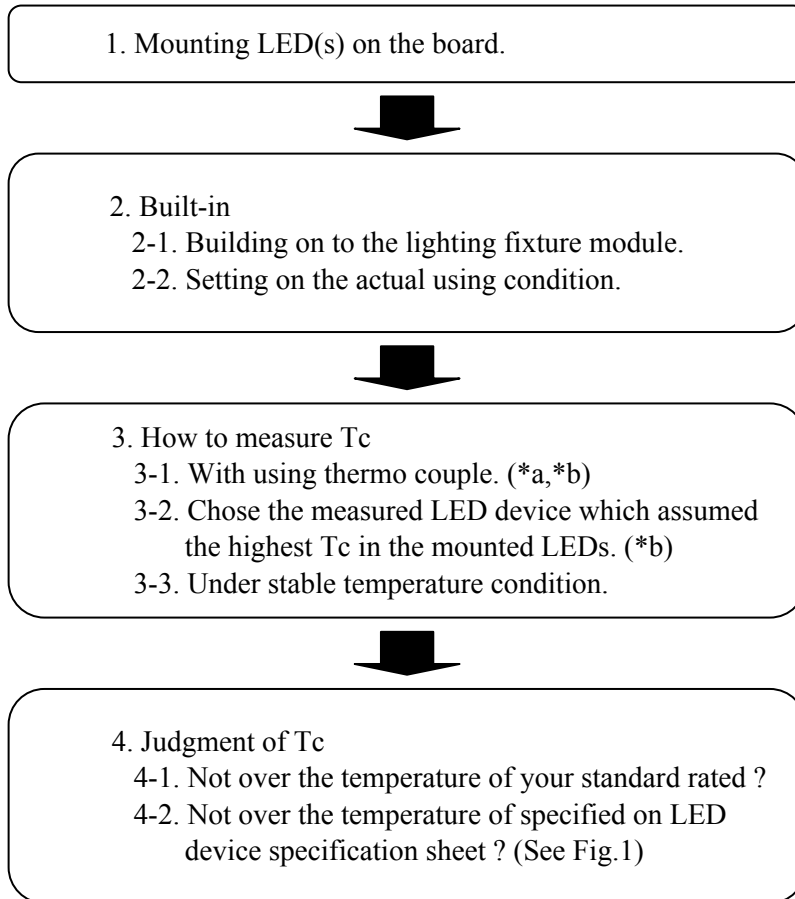

if NOT, go back to procedure No.1 and reconsider.

5. Implemented above condition

*Possible to use as it stands.

5. NOT implemented

- *Reducing forward current
- *Reconsider its design of thermal resistance

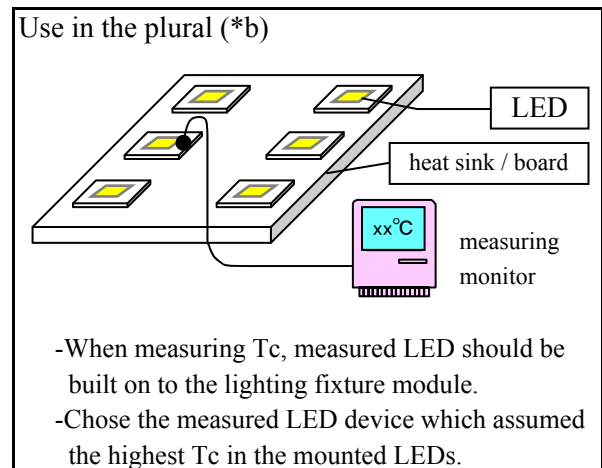
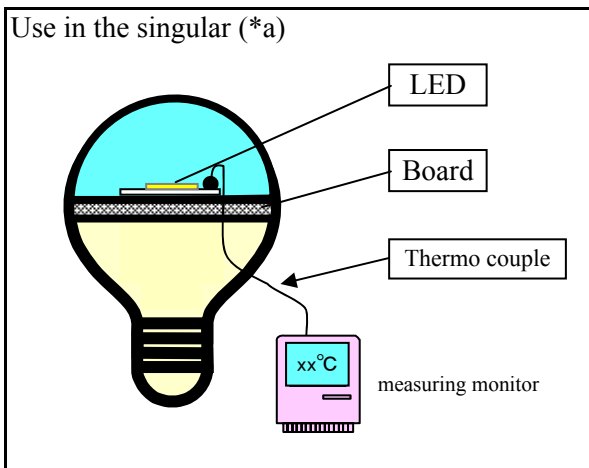

Application Note

Handling

GW5D****M**

4. Manually handling

Use tweezers to catch hold of LEDs at the base substrate part. Do not touch the lens with the tweezers and fingers. Do not press on the lens.

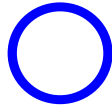

Correct



Wrong

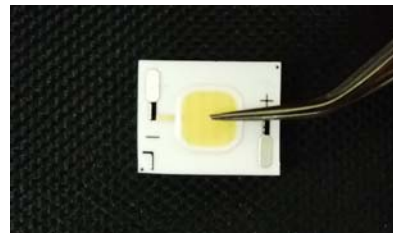

Do not touch the yellow emission resin part.

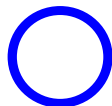

Correct



Wrong

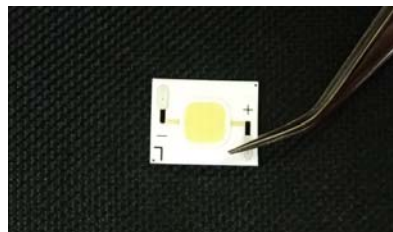

Do not touch both electrodes.

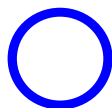

Correct

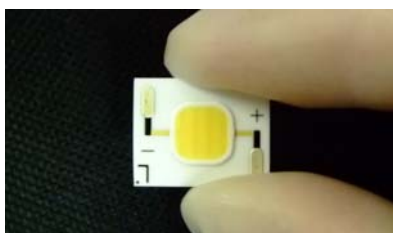

Wrong

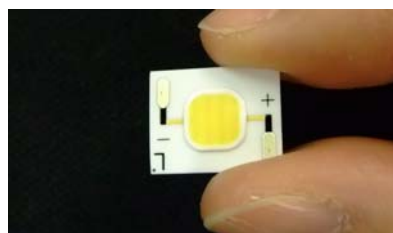

Do not touch with naked finger. Strongly recommended to use a fingertip.

How to mounting

GW5D***M**

Generally, there are 2 ways to mount Mega-Zenigata. Fig.22 shows just the way to attach to heatsink. And Fig.23 shows the way to clip with using cover plate as below.

Fitting Mega-Zenigata LED to the heat sink or board, applying heat conduction sheet (or some kind of grease) between LED device and heat sink is highly recommended to make good use both heat sink and LED device as its potential.

<Fig.22> adhering

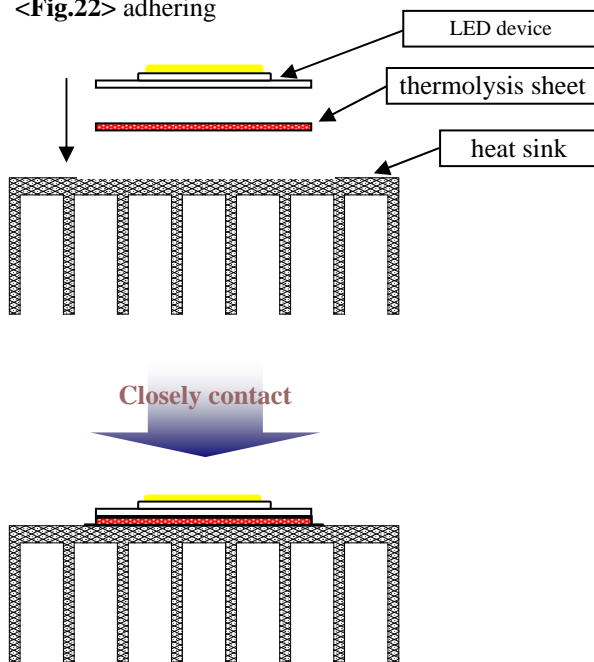

<Fig.23> clipping

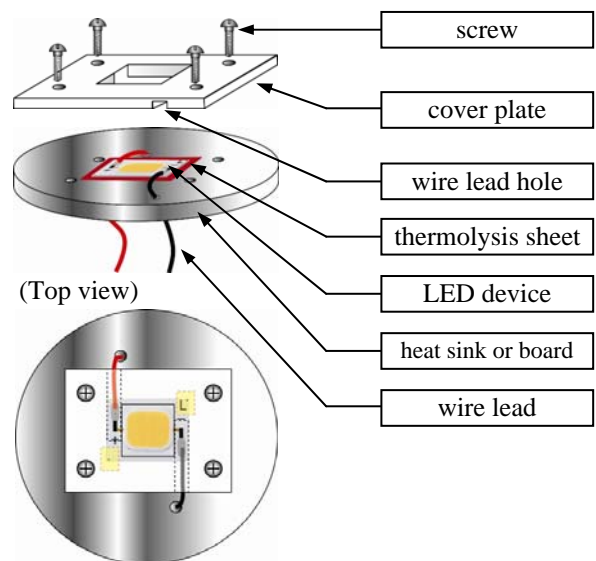

Remarks:

Applying heat conduction sheet or grease, it must be absoluteness adherence between LED device and heat sink. Please do not arise any air holes or bubbles between for each conduct surface to keep good heat conductivity.

As for the rest, follow the instructions or specifications of adhesive sheet and grease issued by its manufacturer.

Example of adhesion items

Maker	Part number	Product outline
Denki Kagaku Kogyo Kabushikikaisha	DKN-***HT	Acrylic adhesion sheet
Dow Corning Toray Co., Ltd.	SE 9184 WHITE RTV	Silicon adhesion bond

These are third-party maker and SHARP can not warranty the use of any of these items with our LED products.

Instruction

GW5D****M**

1 Storage conditions

Please follow the conditions below.

- Before opened: Temperature 5 ~ 30 °C, Relative humidity less than 60 %.
(Before opened LED should be used within a year)
- After opened: Temperature 5 ~ 30 °C, Relative humidity less than 60 %.
(Please apply soldering within 1 week)
- After opened LED should be kept in an aluminum moisture proof bag with a moisture absorbent material (silica gel).
- Avoid exposing to air with corrosive gas.

If exposed, electrode surface would be damaged, which may affect soldering.

2 Usage conditions

The products are not designed for the use under any of the following conditions.

Please confirm their performance and reliability well enough if you use under any of the following conditions;

- In a place with a lot of moisture, dew condensation, briny air, and corrosive gas.
(Cl, H₂S, NH₃, SO₂, NO_x, etc.)
- Under the direct sunlight, outdoor exposure, and in a dusty place.
- In water, oil, medical fluid, and organic solvent.

3 Heat radiation

If the forward current (I_F) is applied to single-state module at any current, there is a risk of damaging module or emitting smoke.

Equip with specified heat radiator, and avoid heat stuffed inside the module.

4 Installation

Material of board is alumina ceramic. If installed inappropriately, trouble of no radiation may occur due to board crack or overheat. Please take particular notice for installing method.

Further information on installation, refer to the following cautions.

- Apply thermolysis adhesive, adhesive sheet or peculiar connector when mounted on heat radiator.
In case of applying adhesive or adhesive sheet only, check the effectiveness and reliability before fixing.
If LED comes off from the heat radiator, unusual temperature rise entails hazardous phenomena including device deterioration, coming off of solder at leads, and emitting smoke.
- When LED device is mechanically fixed or locked, Please take it into consideration regarding method of attach due to fail from stress.
- Avoid convexly uneven boards.
Those convex boards are subject to substrate cracking or debasement of heat release.
- It is recommended to apply adhesive or adhesive sheet with high thermal conductivity to radiate heat effectively.
- Please take care about the influence of color change of adhesive or adhesive sheet in initial and long term period, which may affect light output or color due to change of reflectance from backside.

5 Module surface strength

Module surface is subject to mechanical stress. Applying stress to surface of modules results in damage on resin and internal failure. Please do not pressurize on the part of resin.

Instruction

GW5D****M**

6 Connecting method

In case of solder connecting method, follow the conditions mentioned below.

- Use Soldering iron with thermo controller (tip temperature 380 °C), within 5 seconds per one place.
- Secure the solder wettability on whole solder pad and leads.
- During the soldering process, put the ceramic board on materials whose conductivity is poor enough not to radiate heat of soldering.
- Warm up (with using a heated plate) the substrate is recommended before soldering.
- Avoid touching a part of resin with soldering iron.
- This product is not designed for reflow and flow soldering.
- Avoid such lead arrangement as applying stress to solder-applied area.
- Please do not detach solder and make re-solder.
- Please solder evenly on each electrodes.
- Please prevent flux from touching to resin.

7 Static electricity

This product is subject to static electricity, so take measures to cope with it.
Install circuit protection device to drive circuit, if necessary.

8 Drive method

- Any reverse voltage cannot be applied to LEDs when they are in operation or not.
Design a circuit so that any flow of reverse or forward voltage can not be applied to LEDs when they are out of operation.
- Module is composed of LEDs connected in both series and parallel.
Constant voltage power supply runs off more than specified current amount due to lowered V_F caused by temperature rise.
Constant current power supply is recommended to drive.

9 Cleaning

Avoid cleaning, since silicone resin is eroded by cleaning.

10 Color-tone variation

Chromaticity of this product is monitored by integrating sphere right after the operation.
Chromaticity varies depending on measuring method, light spread condition, or ambient temperature.
Please verify your actual conditions before use.

11 Safety

- Looking directly at LEDs for a long time may result in hurt your eyes.
- In case that excess current (over ratings) are supplied to the device, hazardous phenomena including abnormal heat generation, emitting smoke, or catching fire can be caused.
Take appropriate measures to excess current and voltage.
- In case of solder connecting method, there is a possibility of fatigue failure by heat.
Please fix the leads in such case to protect from short circuit or leakage of electricity caused by contact.
- Please confirm the safety standards or regulations of application devices.
- Please careful not to injure your hand by edge of ceramic substrate.

12 The formal specification must be exchanged before beginning your mass production.

Optics

GW5D***M**

•Optical characteristics 1

The light distribution emitted from GW5D***C***M** may be described in different ways. Using geometric optics, the light may be described using rays. Rays of light near the LED are referred to as near field. Rays in the near field may cross, resulting in changing patterns of light in the region. Rays of light at a distance far from the source referred to as far field.

<Near field>

Typically the near field is described as a distance that is less than fifteen times the source or aperture size.

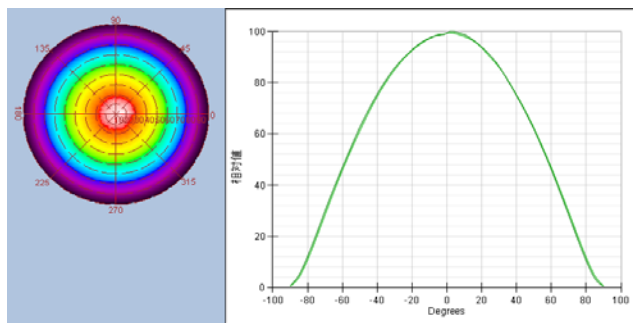

NFP luminous distribution

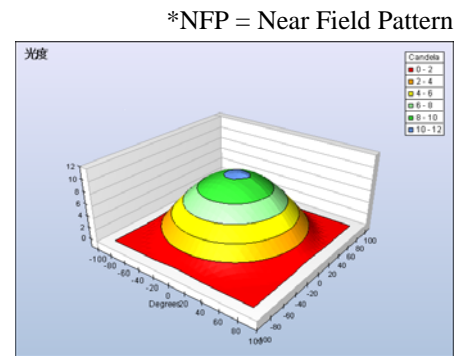

NFP 3D luminous distribution

<Far field>

The far field describes rays from the source, at a distance described as approximately fifteen times or greater that of the source size.

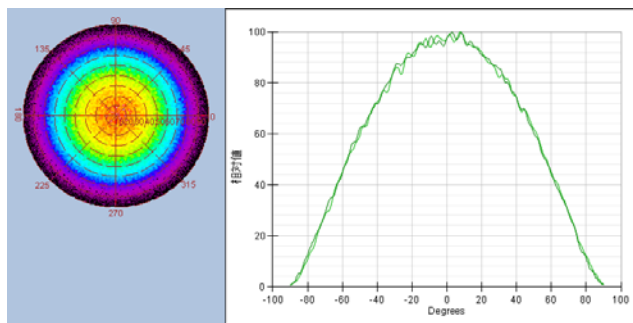

FFP luminous distribution

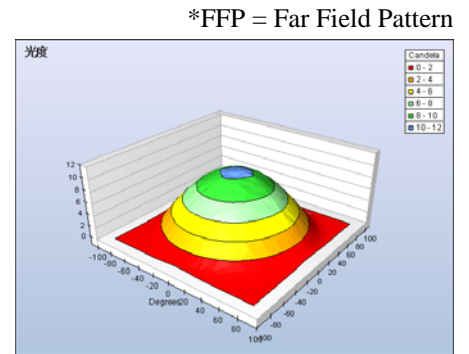

FFP 3D luminous distribution

<Mathematical data value for calculation>

Mathematical data and calculation for the above is available upon request. Please contact Sharp or your Sharp representative.

Optics

GW5D***M**

•Optical characteristics 2

The light distribution emitted from GW5D*A**M** may be described in different ways. Using geometric optics, the light may be described using rays. Rays of light near the LED are referred to as near field. Rays in the near field may cross, resulting in changing patterns of light in the region. Rays of light at a distance far from the source referred to as far field.

<Near field>

Typically the near field is described as a distance that is less than fifteen times the source or aperture size.

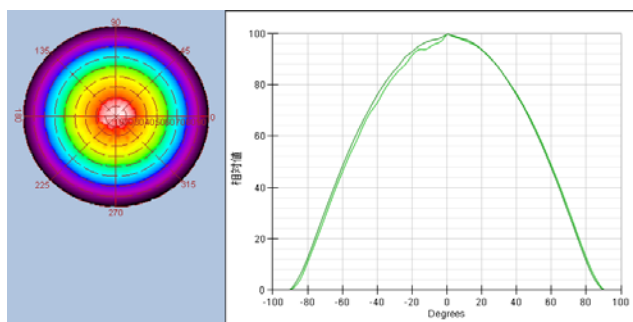

NFP luminous distribution

*NFP = Near Field Pattern

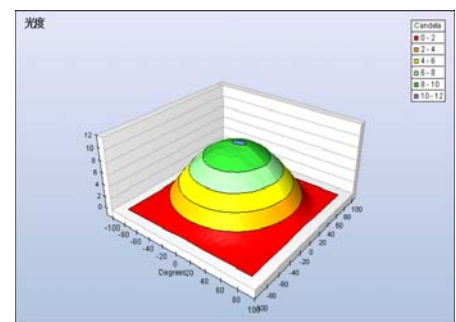

NFP 3D luminous distribution

<Far field>

The far field describes rays from the source, at a distance described as approximately fifteen times or greater that of the source size.

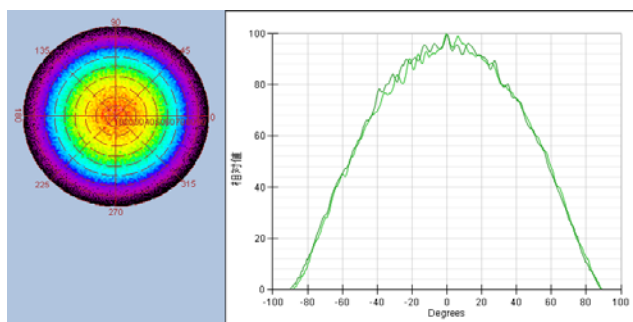

FFP luminous distribution

*FFP = Far Field Pattern

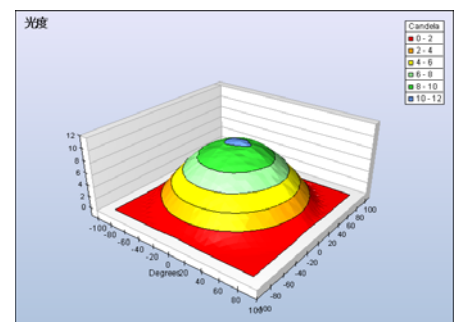

FFP 3D luminous distribution

<Mathematical data value for calculation>

Mathematical data and calculation for the above is available upon request. Please contact Sharp or your Sharp representative.

Optics

GW5D****M**



address: Unit531, 5/F, Enterprise place, Hong Kong
Science park, Shatin N.T

Country: Hong Kong

Tel: +852 2793 5976

Fax: +852 2793 1696

e-mail: sales@diffraction-optics.com

web-site: <http://www.diffraction-optics.com>

Side view



Type No: P8215

Type No: P8256

Type No: P8264

Type No: P8249

Top view

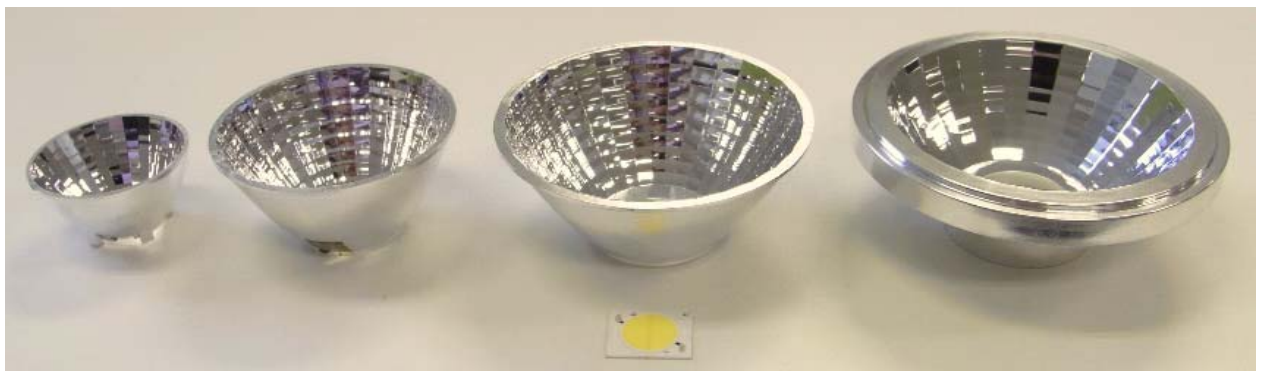

Type No: P8215

Type No: P8256

Type No: P8264

Type No: P8249

Opto Specification

Opto/EC Group



NORTH AMERICA

Sharp Microelectronics of the Americas
5700 NW Pacific Rim Blvd.
Camas, WA 98607, U.S.A.
Phone: (1) 360-834-8700
Fax: (1) 360-834-8903
www.sharpsma.com

TAIWAN

Sharp Electronic Components
(Taiwan) Corporation
8F-A, No. 16, Sec. 4, Nanking E. Rd.
Taipei, Taiwan, Republic of China
Phone: (886) 2-2577-7341
Fax: (886) 2-2577-7326/2-2577-7328

CHINA

Sharp Microelectronics of China
(Shanghai) Co., Ltd.
28 Xin Jin Qiao Road King Tower 16F
Pudong Shanghai, 201206 P.R. China
Phone: (86) 21-5854-7710/21-5834-6056
Fax: (86) 21-5854-4340/21-5834-6057
Head Office:
No. 360, Bashen Road,
Xin Development Bldg. 22
Waigaoqiao Free Trade Zone Shanghai
200131 P.R. China
Email: smc@china.global.sharp.co.jp

EUROPE

Sharp Microelectronics Europe
Division of Sharp Electronics (Europe) GmbH
Sonninstrasse 3
20097 Hamburg, Germany
Phone: 49 (0)180 507 35 07
Fax: (49) 40-2376-2232
www.sharpsme.com

SINGAPORE

Sharp Electronics (Singapore) PTE., Ltd.
438A, Alexandra Road, #05-01/02
Alexandra Technopark,
Singapore 119967
Phone: (65) 271-3566
Fax: (65) 271-3855

KOREA

Sharp Electronic Components
(Korea) Corporation
RM 501 Geosung B/D, 541
Dohwa-dong, Mapo-ku
Seoul 121-701, Korea
Phone: (82) 2-711-5813 ~ 8
Fax: (82) 2-711-5819

JAPAN

Sharp Corporation
Electronic Components & Devices
22-22 Nagaïke-cho, Abeno-Ku
Osaka 545-8522, Japan
Phone: (81) 6-6621-1221
Fax: (81) 6117-725300/6117-725301
www.sharp-world.com

HONG KONG

Sharp-Roxy (Hong Kong) Ltd.
Level 26, Tower 1, Kowloon Commerce Centre,
No. 51, Kwai Cheong Road, Kwai Chung,
New Territories, Hong Kong
Phone: (852) 28229311
Fax: (852) 28660779
www.sharp.com.hk
Shenzhen Representative Office:
Room 602-603, 6/F,
International Chamber of Commerce Tower,
168 Fuhua Rd. 3, CBD,
Futian District, Shenzhen 518048,
Guangdong, P.R. China
Phone: (86) 755-88313505
Fax: (86) 755-88313515

SPECIFICATIONS ARE SUBJECT TO CHANGE WITHOUT NOTICE.

Suggested applications (if any) are for standard use; See Important Restrictions for limitations on special applications. See Limited Warranty for SHARP's product warranty.

The Limited Warranty is in lieu, and exclusive of, all other warranties, express or implied.

ALL EXPRESS AND IMPLIED WARRANTIES, INCLUDING THE WARRANTIES OF MERCHANTABILITY, FITNESS FOR USE AND FITNESS FOR A PARTICULAR PURPOSE, ARE SPECIFICALLY EXCLUDED. In no event will SHARP be liable, or responsible in any way, for any incidental or consequential economic or property damage.

Revision record

GW5D****M**

Date	Doc. Number	Page	Contents	
Feb-8 2011	EAN-110201			Tentative

Application Note