

LQ104V1DG5A LCD Module

Product Specification

October 2008

VGA Module featuring
350 nits brightness, and 500:1 contrast.
Full Specifications Listing.

PREPARED BY : DATE	 MOBILE LIQUID CRYSTAL DISPLAY GROUP SHARP CORPORATION SPECIFICATION	SPEC No. LD-20407B
APPROVED BY : DATE		FILE No.
		ISSUE : Oct.15.2008
		PAGE : 21 pages
		APPLICABLE GROUP MOBILE LIQUID CRYSTAL DISPLAY GROUP

DEVICE SPECIFICATION FOR
TFT-LCD Module
MODEL No.
LQ104V1DG5A

These parts have corresponded with the RoHS directive.

CUSTOMER'S APPROVAL

DATE _____

BY _____

PRESENTED

BY 

K. Shiono
General manager
ENGINEERING DEPARTMENT
MOBILE LIQUID CRYSTAL DISPLAY DIVISION III
MOBILE LIQUID CRYSTAL DISPLAY GROUP
SHARP CORPORATION

1. Application

This specification applies to color TFT-LCD module, LQ104V1DG5A.

These specification sheets are the proprietary product of SHARP CORPORATION("SHARP) and include materials protected under copyright of SHARP. Do not reproduce or cause any third party to reproduce them in any form or by any means, electronic or mechanical, for any purpose, in whole or in part, without the express written permission of SHARP.

The device listed in specification sheets was designed and manufactured for use in general electronic equipment.

In case of using the device for applications such as control and safety equipment for transportation(aircraft, trains, automobiles, etc.), rescue and security equipment and various safety related equipment which require higher reliability and safety, take into consideration that appropriate measures such as fail-safe functions and redundant system design should be taken.

Do not use the device for equipment that requires an extreme level of reliability, such as aerospace applications, telecommunication equipment(trunk lines), nuclear power control equipment and medical or other equipment for life support.

SHARP assumes no responsibility for any damage resulting from the use of the device which does not comply with the instructions and the precautions specified in these specification sheets.

Confirm "11. Handling Precautions "(page 15 and 16) item when you use the device.

Contact and consult with a SHARP sales representative for any questions about this device.

2. Overview

This module is a color active matrix LCD module incorporating amorphous silicon TFT (Thin Film Transistor). It is composed of a color TFT-LCD panel, driver ICs, control circuit and power supply circuit and a backlight unit. Graphics and texts can be displayed on a 640 × 3 × 480 dots panel with 262,144 colors by supplying 18 bit data signal (6bit/color), four timing signals,+3.3V/ +5.0V DC supply voltage for TFT-LCD panel driving and supply voltage for backlight.

The TFT-LCD panel used for this module is a low-reflection and higher-color-saturation type.

Therefore, this module is also suitable for the multimedia use.

Optimum viewing direction is 6 o'clock.

Backlight-driving DC/AC inverter is not built in this module.

3. Mechanical Specifications

Parameter	Specifications	Unit
Display size	26 (10.4") Diagonal	cm
Active area	211.2(H) × 158.4(V)	mm
Pixel format	640(H) × 480(V)	pixel
	(1 pixel = R + G + B dots)	
Pixel pitch	0.330(H) × 0.330(V)	mm
Pixel configuration	R,G,B vertical stripe	
Display mode	Normally white	
Unit outline dimensions *1	246.5(W) × 179.4(H) × 15.5max(D)	mm
Mass	620(max)	g
Surface treatment	Anti-glare and hard-coating 3H	

*1.Note: excluding backlight cables.

Outline dimensions is shown in page 20.

4. Input Terminals

4-1. TFT-LCD panel driving

	Using connector	: DF9MA-31P-1V(32) (Hirose Electric Co., Ltd.)
CN1	Corresponding connector :	DF9-31S-1V(32) (")
1		DF9A-31S-1V(22) (")
2		DF9B-31S-1V(32) (")
		DF9M-31S-1V(32) (")
CN1 pin arrangement from module surface (Transparent view)		() Please do not use it besides corresponding connector.

Pin No.	Symbol	Function	Remark
1	GND		
2	CK	Clock signal for sampling each data signal	
3	Hsync	Horizontal synchronous signal	【Note1】
4	Vsync	Vertical synchronous signal	【Note1】
5	GND		
6	R0	R E D data signal(LSB)	
7	R1	R E D data signal	
8	R2	R E D data signal	
9	R3	R E D data signal	
10	R4	R E D data signal	
11	R5	R E D data signal(MSB)	
12	GND		
13	G0	G R E E N data signal(LSB)	
14	G1	G R E E N data signal	
15	G2	G R E E N data signal	
16	G3	G R E E N data signal	
17	G4	G R E E N data signal	
18	G5	G R E E N data signal(MSB)	
19	GND		
20	B0	B L U E data signal(LSB)	
21	B1	B L U E data signal	
22	B2	B L U E data signal	
23	B3	B L U E data signal	
24	B4	B L U E data signal	
25	B5	B L U E data signal(MSB)	
26	GND		
27	ENAB	Signal to settle the horizontal display position	【Note2】
28	Vcc	+ 3.3/5.0V power supply	
29	Vcc	+ 3.3/5.0V power supply	
30	R/L	Horizontal display mode select signal	【Note3】
31	U/D	Vertical display mode select signal	【Note4】

The shielding case is connected with GND.

【Note1】 480 line, 400 line or 350 line mode
is selected by the polarity combination
of the both synchronous signals.

Mode	480 lines	400 lines	350 lines
Hsync	Negative	Negative	Positive
Vsync	Negative	Positive	Negative

【Note2】 The horizontal display start timing is settled in
accordance with a rising timing of ENAB signal. In case ENAB is fixed “Low”, the horizontal start
timing is determined as described in 7-2. Do not keep ENAB “High” during operation.

【Note3】 【Note4】



R/L=High, U/D=Low



R/L=Low, U/D=Low



R/L=High, U/D=High



R/L=Low, U/D=High

4-2. Backlight driving

Using connector : BHR-02(8.0)VS-1N (JST)

CN2

Corresponding connector : SM02(8.0)B-BHS (JST)

Pin no.	Symbol	Function	Cable color
1	V_{HIGH}	Power supply for lamp (High voltage side)	Pink
3	V_{LOW}	Power supply for lamp (Low voltage side)	White

5. Absolute Maximum Ratings

Parameter	Symbol	Condition	Ratings	Unit	Remark
Input voltage	V_I	Ta=25	- 0.3 ~ Vcc + 0.3	V	【Note1】
+5V supply voltage	Vcc	Ta=25	0 ~ + 6	V	
Storage temperature	Tstg	-	- 30 ~ + 70		【Note2】
Operating temperature (Ambient)	Topa	-	- 10 ~ + 65		【Note3】

【Note1】 CK, R0 ~ R5, G0 ~ G5, B0 ~ B5, Hsync, Vsync, ENAB, R/L, U/D

【Note2】 Humidity : 95%RH Max. at Ta 40 .

Maximum wet-bulb temperature at 39 or less at Ta>40 .

No condensation.

【Note3】 There is a possibility of causing deterioration in the irregularity and others of the screen and the display fineness when preserving or using it from 60 to 70 .

6. Electrical Characteristics

6-1. TFT-LCD panel driving

Ta = 25

Parameter		Symbol	Min.	Typ.	Max.	Unit	Remark
Power Supply	Supply voltage	V _{CC}	+3.0	+3.3 +5.0	+5.5	V	【Note1】
	Current dissipation	I _{CC}	-	210	300	mA	V _I =3.3V 【Note2】
I _{CC}		-	140	200	mA	V _I =5.0V 【Note2】	
Permissive input ripple voltage		V _{RF}	-	-	100	mVp-p	
Input voltage (Low)		V _{IL}	-	-	0.8	V	【Note3】
Input voltage (High)		V _{IH}	2.1	-	-	V	
Input current (low)		I _{OL1}	-	-	1.0	μA	V _I =0V 【Note4】
		I _{OL2}			10	μA	V _I =0V 【Note5】
		I _{OL3}	-	-	800	μA	V _I =0V 【Note6】
Input current (High)		I _{OH1}	-	-	1.0	μA	V _I =V _{CC} 【Note7】
		I _{OH2}			300	μA	V _I =V _{CC} 【Note8】
		I _{OH3}	-	-	800	μA	V _I =V _{CC} 【Note9】

【NOTE 1】

V_{CC}-turn-on conditions

- 0 < T₁ 15 ms
- 0 < T₂ 10 ms
- 0 < T₃ 100 ms
- 0 < T₄ 1 s
- T₅ > 200 ms

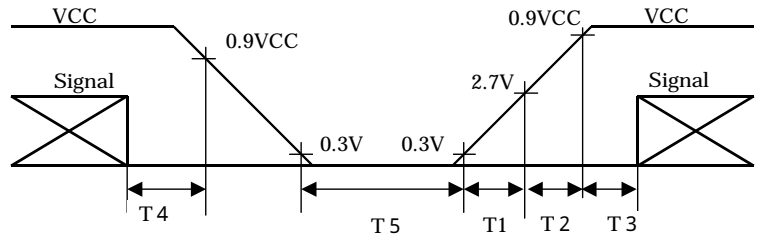

V_{CC}-dip conditions

- 1) 2.5V V_{CC}
t_d 10 ms
- 2) V_{CC} < 2.5V
V_{CC}-dip condition should also follow the V_{CC}-turn-on conditions.

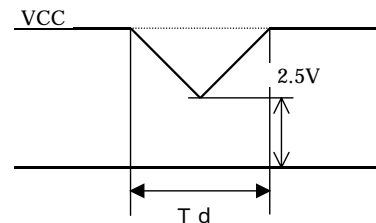

【Note2】 Typical current situation : 16-gray-bar pattern.

480 line mode/V_{CC}=+3.3V/ + 5.0V

【Note3】 CK, R0~R5, G0~G5, B0~B5, Hsync, Vsync, ENAB, R/L, U/D

【Note4】 CK, R0~R5, G0~G5, B0~B5, Hsync, Vsync,

【Note5】 U/D, ENAB

【Note6】 R/L

【Note7】 CK, R0~R5, G0~G5, B0~B5, Hsync, Vsync, R/L

【Note8】 ENAB

【Note9】 U/D

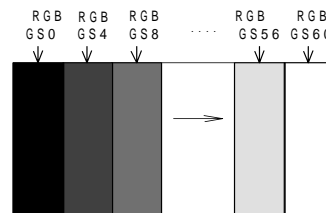

6-2. Backlight driving

The backlight system is an edge-lighting type with double CCFT (Cold Cathode Fluorescent Tube).

The characteristics of single lamp are shown in the following table.

(It is usually required to measure under the following condition. $I_L=6.0\text{mA}$, $T_a=25 \pm 2$, $f_L=60\text{kHz}$.)

Parameter	Symbol	Min.	Typ.	Max.	Unit	Remark
Lamp current	I_L	3.5	6.0	7.0	mArms	【Note1】
Lamp power consumption	P_L	-	2.8	-	W	【Note2】
Lamp frequency	f_L	35	60	70	KHz	【Note3】
Kick-off voltage	V_s	-	-	1000	Vrms	$T_a=25$ 【Note4】
		-	-	1450	Vrms	$T_a=-10$ 【Note4】

【Note1】 Lamp current is measured with current meter for high frequency as shown below.

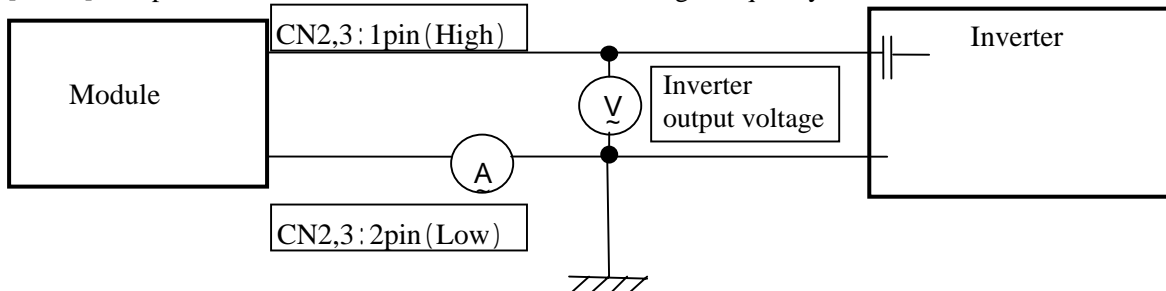

【Note2】 Referential data per one CCFT by calculation. ($I_L \times V_L$)

The data do not include loss at inverter. ($I_L=6.0\text{mArms}$)

【Note3】 Lamp frequency may produce interference with horizontal synchronous frequency, and this may cause beat on the display. Therefore lamp frequency shall be detached as much as possible from the horizontal synchronous frequency and from the harmonics of horizontal synchronous to avoid interference.

【Note4】 The open output voltage of the inverter shall be maintained for more than 1s; otherwise the lamp may not be turned on.

【Note5】 lamp is an article of consumption. Lamp life time is 50,000 hours (reference value) on condition of the following, but this value is not guaranteed.

When lamp (the long side of LCD module) is placed horizontally (landscape position), lamp life time is defined that it applied either or under this condition.

(Continuous turning on at $T_a=25^\circ\text{C}$, $I_L=6.0\text{mA rms}$.)

Brightness becomes 50% of the original value under standard condition.

Kick-off voltage at $T_a=-10^\circ\text{C}$ exceeds maximum value.

(Lamp lifetime may vary if lamp is in portrait position due to the change of mercury density inside the lamp.)

In case of operating under lower temp environment, the lamp exhaustion is accelerated and the brightness becomes lower.

(Continuous operating under lower temp condition for around 1 month may reduce the brightness to half of the original brightness.)

In case of such usage under lower temp environment, periodical lamp exchange is recommended.

【Note6】 The performance of the backlight, for example life time or brightness, is much influenced by the characteristics of the DC-AC inverter for the lamp. When you design or order the inverter, please make sure that a poor lighting caused by the mismatch of the backlight and the inverter (miss-lighting, flicker, etc.) never occur. When you confirm it, the module should be operated in the same condition as it is installed in your instrument.

Be sure to use a back light power supply with the safety protection circuit such as the detection circuit for the excess voltage, excess current and or electric discharge waveform.

Be sure to use the detect circuit by which one side of the CCFT lamps can be controlled independently.

Otherwise, when one side of the CCFT is open, the excess current may possibly be applied to the other side of the lamp.

【Note7】 It is required to have the inverter designed so that to allow the impedance deviation of the two CCFT lamps and the capacity deviation of barast capacitor.

【Note8】 Please make it to the structure not touching directly insulating the high voltage part.

Please stop the circuit by the protection element such as fuses for generation of heat and the ignition prevention, and use a flame resisting and high material for the substrate and the resin material.

【Note9】 Under the environment of 10lx or less, miss-lighting delay may occur.

7. Timing Characteristics of input signals

Timing diagrams of input signal are shown in Fig.1-1, Fig.1-2, and Fig.1-3.

7-1. Timing characteristics

Parameter		Symbol	Mode	Min.	Typ.	Max.	Unit	Remark
Clock	Frequency	1/Tc	all	-	25.18	28.33	MHz	
	High time	Tch	"	5	-	-	ns	
	Low time	Tcl	"	10	-	-	ns	
Data	Setup time	Tds	"	5	-	-	ns	
	Hold time	Tdh	"	10	-	-	ns	
Horizontal sync. signal	Cycle	TH	"	30.00	31.78	-	μs	
			"	750	800	900	clock	
	Pulse width	THp	"	2	96	200	clock	
Vertical sync. signal	Cycle	TV	480	515	525	560	line	
			400	446	449	480	line	
			350	447	449	510	line	
	Pulsewidth	TVp	all	1	-	34	line	
Horizontal display period		THd	"	640	640	640	clock	
Hsync-Clock Phase difference		THc	"	10	-	Tc-10	ns	
Hsync-Vsync Phase difference		TVh	"	0	-	TH-THp	clock	

Note) In case of lower frequency, the deterioration of display quality, flicker etc., may be occurred.

7-2. Horizontal display position

The horizontal display position is determined by the rising edge of ENAB signal.

Parameter		symbol	Min.	Typ.	Max.	Unit	Remark
Enable signal	Setup time	Tes	5	-	Tc-10	ns	
	Pulse width	Tep	2	640	640	clock	
Hsync-Enable signal phase difference		THE	44	-	TH-664	clock	

Note) When ENAB is fixed "Low", the display starts from the data of C104(clock) as shown in Fig.1-1, Fig.1-2, and Fig.1-3.

When the phase difference is below 104 clocks, keep the "High" level of ENAB is signal longer than 104-The clocks. If it will not be kept, the display starts from the data of C104(clock).

7-3. Vertical display position

The vertical display position is automatically centered in the active area at each mode of VGA 480, 400, and 350-line mode, when each mode is selected depending on the polarity of the synchronous signals described in 4-1(Note1).

In 400- and 350-line mode, when vertical synchronous signal TV is timing other than the above-mentioned typical value, a screen display position may shift.

In 400- and 350-line mode, the data in the vertical data invalid period is also displayed, so, inputting all data "0" is recommended during vertical data invalid period.

ENAB signal has no relation to the vertical display position.

Mode	V-data start(TVs)	V-data period(TVd)	V-display start(TVn)	V-display period	Unit	Remark
480	34	480	34	480	line	
400	34	400	443-TV	480	line	
350	61	350	445-TV	480	line	

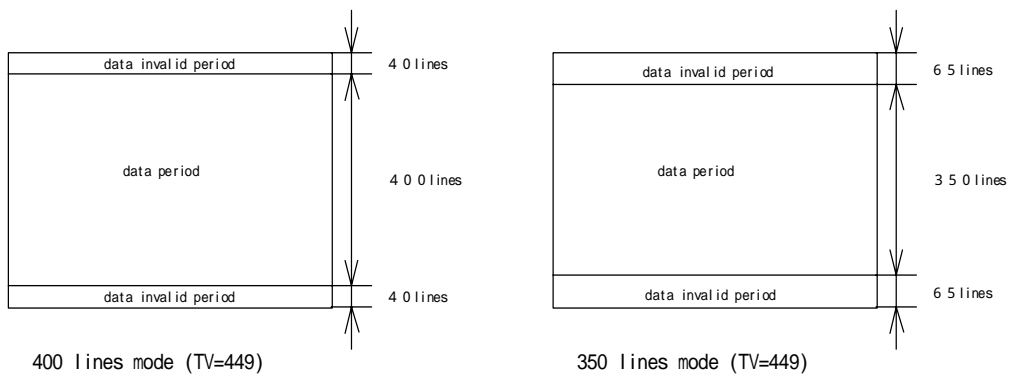

7-4. Input Data Signals and Display Position on the screen

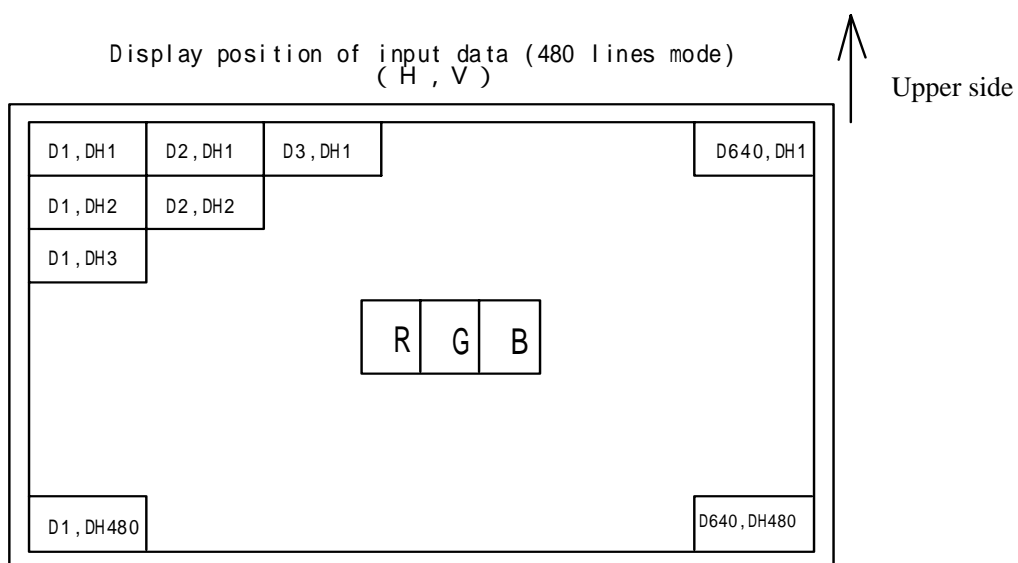

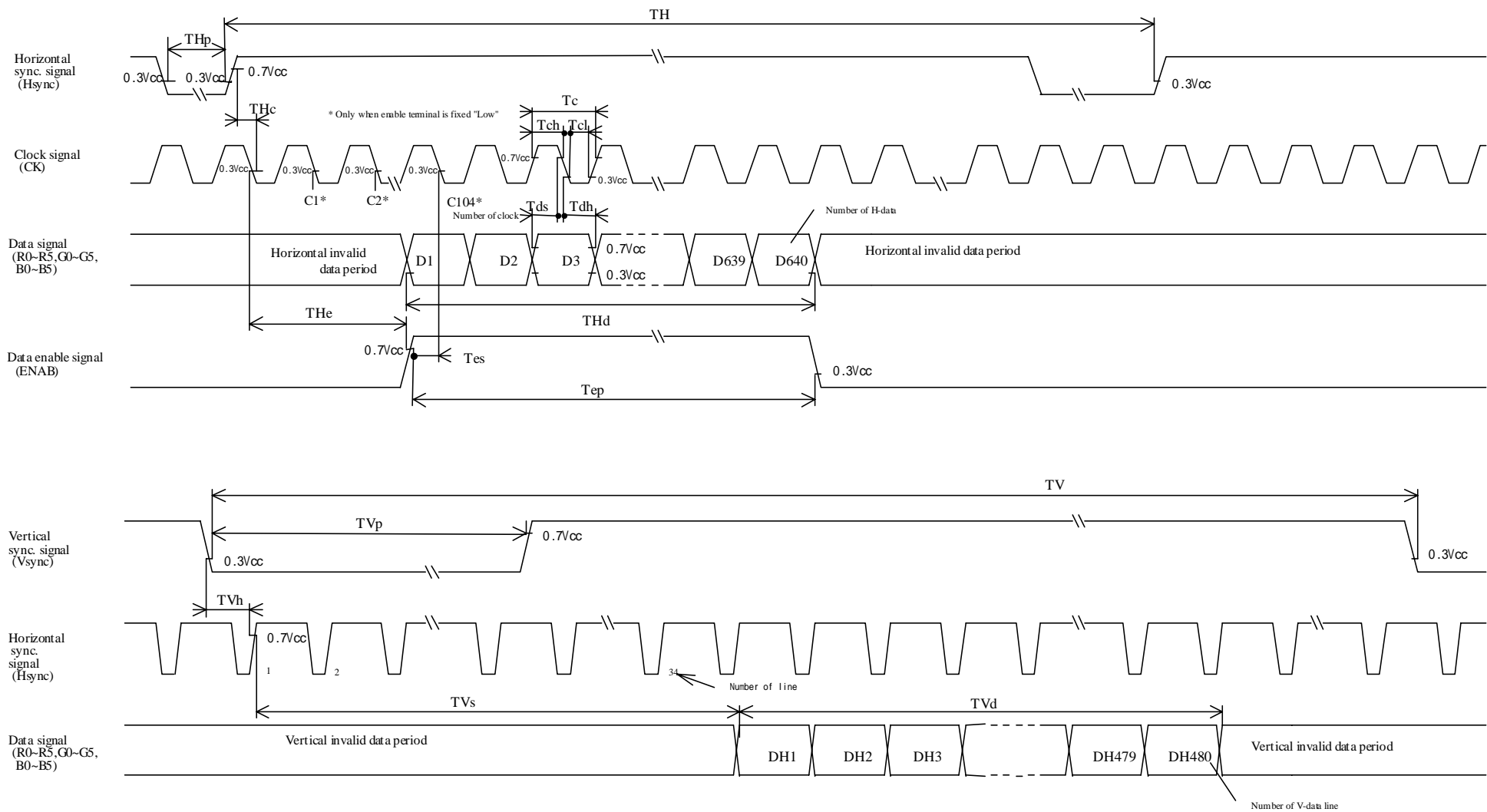

Fig. 1-1 Input signal waveforms (480 line mode)

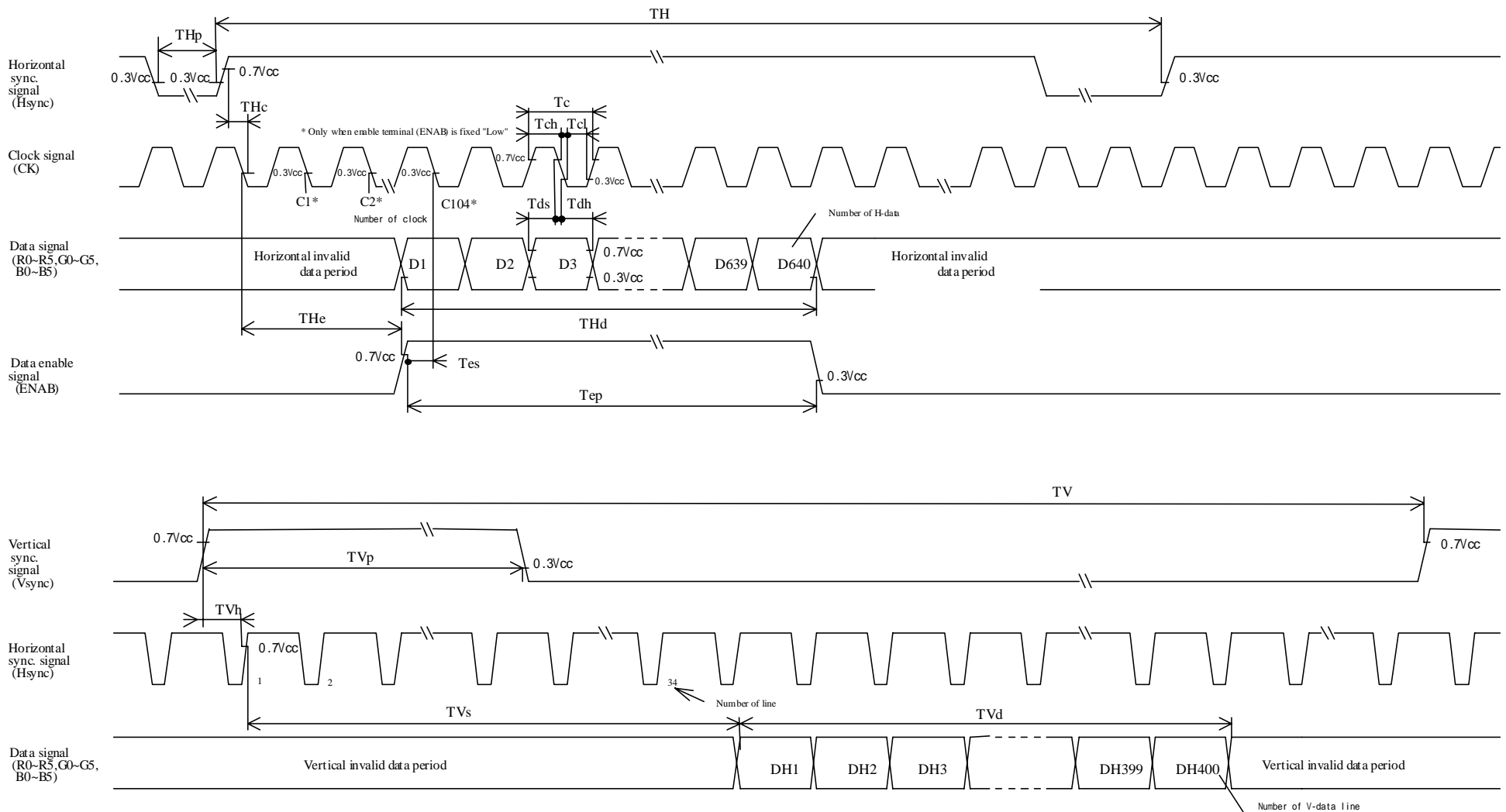

Fig.1-2 Input signal waveforms (400 line mode)

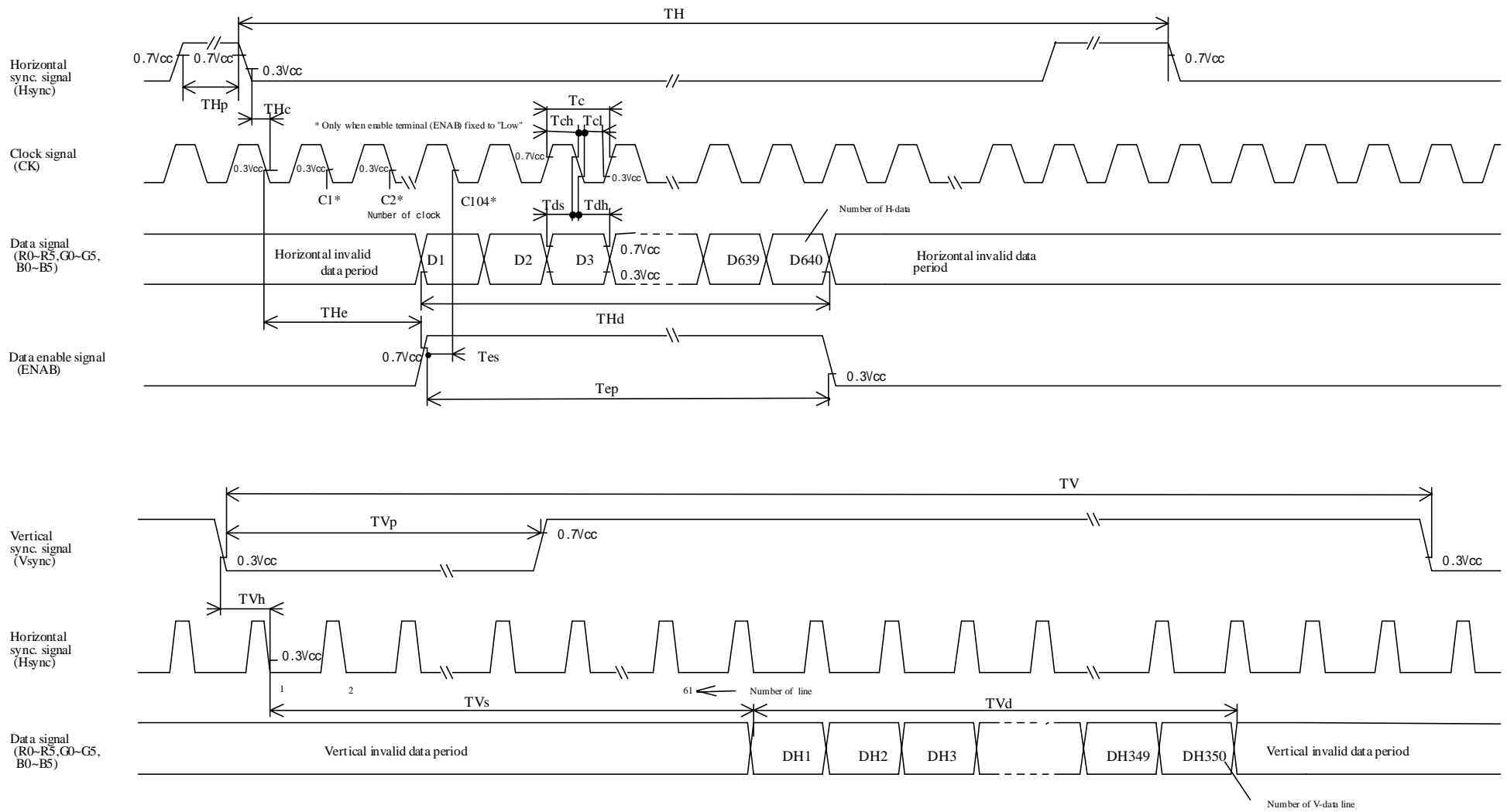

Fig.1-3 Input signal waveforms (350 line mode)

8. Input Signals, Basic Display Colors and Gray Scale of Each Color

	Colors & Gray scale	Data signal																		
		Gray Scale	R0	R1	R2	R3	R4	R5	G0	G1	G2	G3	G4	G5	B0	B1	B2	B3	B4	B5
Basic Color	Black	-	0	0	0	0	0	0	0	0	0	0	0	0	0	0	0	0	0	0
	Blue	-	0	0	0	0	0	0	0	0	0	0	0	0	1	1	1	1	1	1
	Green	-	0	0	0	0	0	0	1	1	1	1	1	1	0	0	0	0	0	0
	Cyan	-	0	0	0	0	0	0	1	1	1	1	1	1	1	1	1	1	1	1
	Red	-	1	1	1	1	1	1	0	0	0	0	0	0	0	0	0	0	0	0
	Magenta	-	1	1	1	1	1	1	0	0	0	0	0	0	1	1	1	1	1	1
	Yellow	-	1	1	1	1	1	1	1	1	1	1	1	1	0	0	0	0	0	0
	White	-	1	1	1	1	1	1	1	1	1	1	1	1	1	1	1	1	1	1
Gray Scale of Red	Black	GS0	0	0	0	0	0	0	0	0	0	0	0	0	0	0	0	0	0	0
	↑	GS1	1	0	0	0	0	0	0	0	0	0	0	0	0	0	0	0	0	0
	Darker	GS2	0	1	0	0	0	0	0	0	0	0	0	0	0	0	0	0	0	0
	↑	↓			↓					↓					↓					
	↓	↓			↓					↓					↓					
	Brighter	GS61	1	0	1	1	1	1	0	0	0	0	0	0	0	0	0	0	0	0
	↓	GS62	0	1	1	1	1	1	0	0	0	0	0	0	0	0	0	0	0	0
	Red	GS63	1	1	1	1	1	1	0	0	0	0	0	0	0	0	0	0	0	0
Gray Scale of Green	Black	GS0	0	0	0	0	0	0	0	0	0	0	0	0	0	0	0	0	0	0
	↑	GS1	0	0	0	0	0	0	1	0	0	0	0	0	0	0	0	0	0	0
	Darker	GS2	0	0	0	0	0	0	0	1	0	0	0	0	0	0	0	0	0	0
	↑	↓			↓					↓					↓					
	↓	↓			↓					↓					↓					
	Brighter	GS61	0	0	0	0	0	0	1	0	1	1	1	1	0	0	0	0	0	0
	↓	GS62	0	0	0	0	0	0	0	1	1	1	1	1	0	0	0	0	0	0
	Green	GS63	0	0	0	0	0	0	1	1	1	1	1	1	0	0	0	0	0	0
Gray Scale of Blue	Black	GS0	0	0	0	0	0	0	0	0	0	0	0	0	0	0	0	0	0	0
	↑	GS1	0	0	0	0	0	0	0	0	0	0	0	0	1	0	0	0	0	0
	Darker	GS2	0	0	0	0	0	0	0	0	0	0	0	0	0	1	0	0	0	0
	↑	↓			↓					↓					↓					
	↓	↓			↓					↓					↓					
	Brighter	GS61	0	0	0	0	0	0	0	0	0	0	0	0	1	0	1	1	1	1
	↓	GS62	0	0	0	0	0	0	0	0	0	0	0	0	0	1	1	1	1	1
	Blue	GS63	0	0	0	0	0	0	0	0	0	0	0	0	1	1	1	1	1	1

0 : Low level voltage, 1 : High level voltage

Each basic color can be displayed in 64 gray scales from 6 bit data signals. According to the combination of total 18 bit data signals, the 262,144-color display can be achieved on the screen.

9. Optical Characteristics

Ta=25 , Vcc=+5V

Parameter		Symbol	Condition	Min	Typ	Max	Unit	Remark
Viewing Angle Range	Horizontal	21, 22	C R > 1 0	60	70	-	Deg.	【Note1,4】
	Vertical	11		35	50	-	Deg.	
		12		45	60	-	Deg.	
Contrast ratio		C R	= 0 °	150	-	-	-	【Note2,4】
			Optimum Viewing Angle	-	500	-	-	
Response Time	Rise	r	= 0 °	-	10	-	ms	【Note3,4】
	Decay	d		-	25	-	ms	
Chromaticity of White		x	= 0 °	-	0.313	-		【Note4】 I _L =6.0mArms
		y		-	0.329	-		
Luminance of white		Y _L		280	350	-	cd/m ²	F _L =60kHz
White Uniformity		w		-	-	1.45	-	【Note5】
Viewing Angle range as a Brightness Definition	Horizontal	21, 22	50% of the maximum brightness	-	40	-	Deg.	【Note1】
	Vertical	11		-	30	-	Deg.	
		12		-	25	-	Deg.	

The measurement shall be executed 30 minutes after lighting at rating. (condition:I_L=6.0mArms, F_L=60KHz)

The optical characteristics shall be measured in a dark room or equivalent state with the method shown in Fig.2 below.

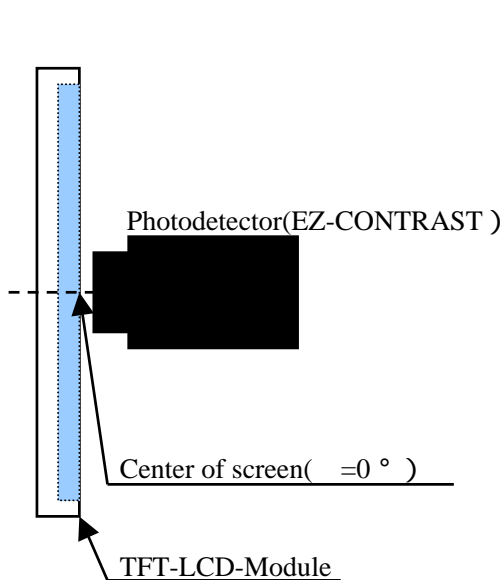

Fig.2-1 Viewing angle measurement method

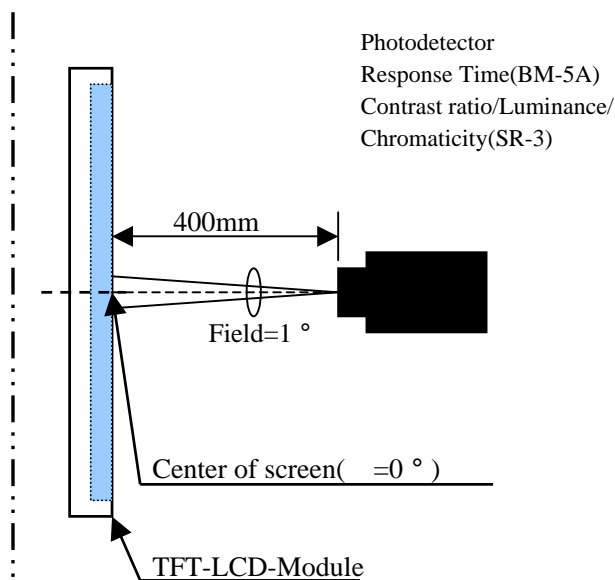
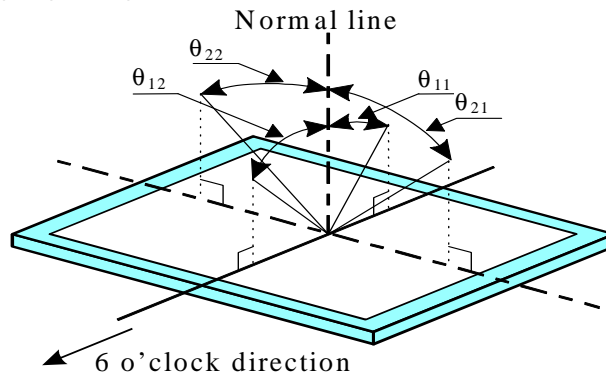

Fig.2-2 Luminance/Contrast ratio/Response time/Chromaticity measurement method

Fig.2 Optical characteristics measurement method

【Note1】 Definitions of viewing angle range:



【Note2】 Definition of contrast ratio:

The contrast ratio is defined as the following.

$$\text{Contrast Ratio (CR)} = \frac{\text{Luminance (brightness) with all pixels white}}{\text{Luminance (brightness) with all pixels black}}$$

【Note3】 Definition of response time:

The response time is defined as the following figure and shall be measured by switching the input signal for "black" and "white" .

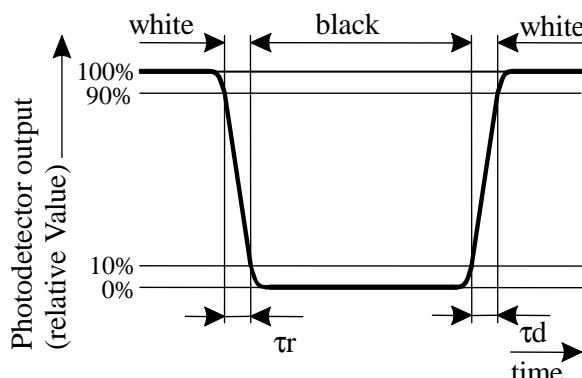

【Note4】 This shall be measured at center of the screen.

【Note5】 Definition of white uniformity:

White uniformity is defined as the following with five measurements (A ~ E).

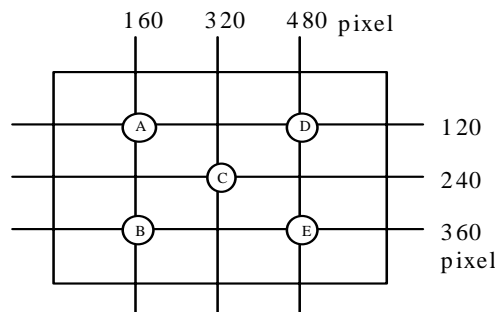

$$w = \frac{\text{Maximum Luminance of five points (brightness)}}{\text{Minimum Luminance of five points (brightness)}}$$

10. Display Quality

The display quality of the color TFT-LCD module shall be in compliance with the Incoming Inspection Standard.

11 . Handling Precautions

- a) Be sure to turn off the power supply when inserting or disconnecting the cable.
- b) Be sure to design the cabinet so that the module can be installed without any extra stress such as warp or twist.
- c) Since the front polarizer is easily damaged, pay attention not to scratch it.
Blow away dust on the polarizer with antistatic N₂ blow.
It is undesirable to wipe off because a polarizer is sensitive.
It is recommended to peel off softly using the adhesive tape when soil or finger oil is stuck to the polarizer.
When unavoidable, wipe off carefully with a cloth for wiping lenses.
- d) Wipe off water drop immediately. Long contact with water may cause discoloration or spots.
- e) When the panel surface is soiled, wipe it with absorbent cotton or other soft cloth.
- f) Since the panel is made of glass, it may break or crack if dropped or bumped on hard surface. Handle with care.
- g) Since CMOS LSI is used in this module, take care of static electricity and injure the human earth when handling.
Observe all other precautionary requirements in handling electric components.
- h) Since there is a circuit board in the module back, stress is not added at the time of a design assembly.
Please make it like. If stress is added, there is a possibility that circuit parts may be damaged.
- i) Protection film is attached to the module surface to prevent it from being scratched. Peel the film off slowly, just before the use, with strict attention to electrostatic charges.
Blow off 'dust' on the polarizer by using an ionized nitrogen.
- j) The polarizer surface on the panel is treated with Anti-Glare for low reflection.
In case of attaching protective board over the LCD, be careful about the optical interface fringe etc. which degrades display quality.
- k) Do not expose the LCD panel to direct sunlight.
Lightproof shade etc. should be attached when LCD panel is used under such environment.
If a light strong against a LCD panel is irradiated, it may lead to degradation of the panel characteristic and display grace may get worse.
- l) Connect GND to 4 place of mounting holes to stabilize against EMI and external noise.
- m) There are high voltage portions on the backlight and very dangerous.
Careless touch may lead to electrical shock.
When exchange lamps or service, turn off the power without tail.
- n) When handling LCD modules and assembling them into cabinets, please be noted that long-term storage in the environment of oxidization or deoxidization gas, and the use of such materials as reagent, solvent, adhesive, resin, etc. which generate these gasses, may cause corrosion, discoloration, degradation of display grace, and abnormalities of operation.
- o) Cold cathode fluorescent lamp in LCD panel contains a small amount of mercury, please follow local ordinances or regulations for disposal.
- p) Be careful of a back light lead not to pull by force at the time of the wiring to an inverter, or line processing.
- q) When install LCD modules in the cabinet, recommended torque value is “ $0.294 \pm 0.02\text{N}\cdot\text{m}$ ($3.0 \pm 0.2\text{kgf}\cdot\text{cm}$)”.
Be sure to confirm it in the same condition as it is installed in your instrument.
- r) Liquid crystal contained in the panel may leak if the LCD is broken.
Rinse it as soon as possible if it gets inside your eye or mouth by mistake.
- s) Notice: Never dismantle the module, because it will cause failure.
Moreover, please do not peel off the tapes other than the creped paper tape (yellow tape) of a protection film pasted to the product and a lamp connector temporary stop.
- t) Be careful when using it for long time with fixed pattern display as it may cause afterimage.
(Please use a screen saver etc., in order to avoid an afterimage.)
- u) Adjusting volume have been set optimally before shipment, so do not change any adjusted value.
If adjusted value is changed, the specification may not be satisfied.
- v) If a minute particle enters in the module and adheres to an optical material, it may cause display non-uniformity issue, etc.
Therefore, fine-pitch filters have to be installed to cooling and inhalation hole if you intend to install a fan.

w) The lamp used for this product is very sensitive to the temperature.

Luminance decreases rapidly when it is used for a long time or repeatedly under the environment of the low temperature or the module is being cooled.

Please avoid the continuous or repeatedly use of it such an environment.

It may decrease up to 50% of the initial luminance in about one month under the low temperature environment.

Please consult our company when it is used under the environment like above mentioned.

12. Packing form

Product countries / Areas	JAPAN, CHINA
Piling number of cartons	5 (MAX)
Packing quantity in one carton	20pcs
Carton size [mm]	494(W) × 326(D) × 433(H)
Total mass of one carton filled with full modules	15.6kg (MAX)
Packing form is shown	Page 21

13 . Reliability test items

No.	Test item	Conditions	Remark
1	High temperature storage test	Ta=70 240h	Panel surface
2	Low temperature storage test	Ta= -30 240h	
3	High temperature & high humidity operation test	Ta=40 ; 95%RH 240h (No condensation)	
4	High temperature operation test	Ta=65 240h	Panel surface
5	Low temperature operation test	Ta= -10 240h	
6	Vibration test (non- operating)	Frequency: 10 ~ 57Hz/Vibration width (one side):0.075mm : 57 ~ 500Hz/Gravity:9.8m/s ² Sweep time : 11 minutes Test period : 3 hours (1 hour for each direction of X,Y,Z)	
7	Shock test (non- operating)	Max. gravity : 490m/s ² Pulse width : 11ms, half sine wave Direction : ± X, ± Y, ± Z once for each direction.	
8	ESD test	Contact discharge (150pF 330) non-operating = ± 10kV, operating = ± 8kV Atmospheric discharge (150pF 330) non-operating = ± 20kV, operating = ± 15kV	
9	EMI	Measurement in 10m site Display position on the screen = "H"(full-screen) GND to 4 place = un-connect, Vcc / Vsignal = typ.	VCCI (Class B)

[Result Evaluation Criteria]

Under the display quality test conditions with normal operation state, these shall be no change which may affect practical display function. (normal operation state : Temperature:15 ~ 35 , Humidity:45 ~ 75%, Atmospheric pressure:86 ~ 106kpa)

14.Others

14-1. Label

Lot No. Label:

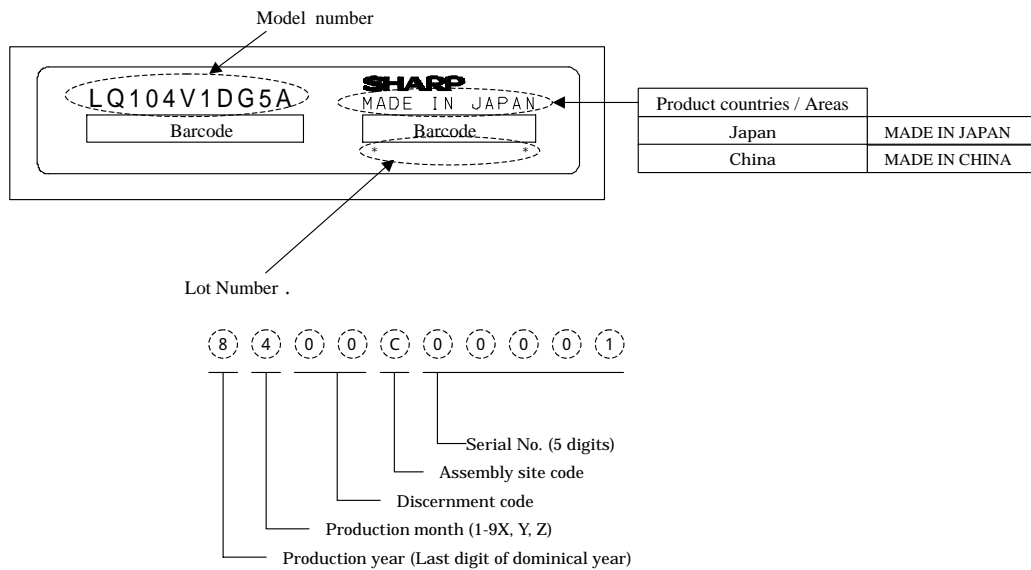

Packing box Label:

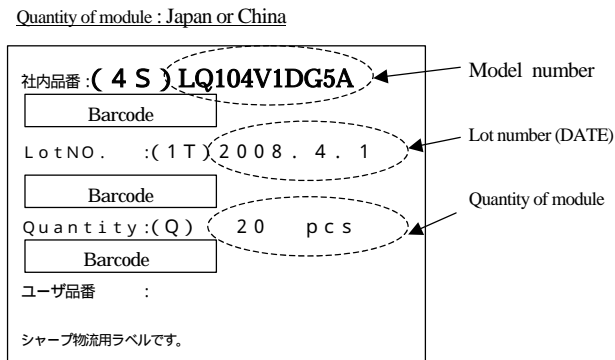

The figure right below is written to the packing box of the settlement for the RoHS restriction.
 R.C. (RoHS Compliance) means it suits the RoHS directive.
 This LCD module is compliant with RoHS Directive.

Internal Use Only
R . C .

14-2. The chemical ozone depleting substance is not used.

14-3. Cold cathode fluorescent lamp in LCD panel contains a small amount of mercury, please follow local ordinances or regulations for disposal. (It marks on the back of the module.)

• COLD CATHODE FLUORESCENT LAMP IN LCD PANEL
CONTAINS A SMALL AMOUNT OF MERCURY, PLEASE FOLLOW
LOCAL ORDINANCES OR REGULATIONS FOR DISPOSAL.

• 当該液晶ディスプレイパネルは蛍光管が組込まれていますので、地方自治体の条例、または、規則に従って
廃棄してください。

14-4. Keeping environment condition

Temperature 0 ~ 40

Relative humidity 95% or less

【Note】 • Please manage as a mean value of the keeping temperature humidity environment referring to the following condition.

Summer time 20 ~ 35 85% or less

Winter 5 ~ 15 85% or less

• Please manage in total within 240 hours at the time kept under the environment of 40 ,95%RH.

Direct sunshine

Please keep it in the state of wrapping or the darkroom so that direct sunshine should not strike directly into the product.

Atmosphere

Please do not keep it in the place with the danger of the generation of the causticity gas and the volatile solvent.

Asking for be dewy prevention

- Please do not put directly on the floor, and keep the wrapping box on the palette or the stand to avoid the be dewy. Moreover, please arrange it in a constant direction correctly to improve ventilation under the palette.
- Please separate from the wall in the storage warehouse and keep it.
- Please note that ventilation is improved and consider the installation such as ventilators in the warehouse.
- Please manage so that there is no rapid temperature change more than natural environment.

Keeping period

Please make it to keeping within one year under the above-mentioned keeping condition.

14-5. If any problem occurs in relation to the description of this specification, it shall be resolved through discussion with spirit of cooperation.

Procedure to backlight replacement

Lamp which is used in the LCD module is consumable goods. When the lamp replacement is needed due to the expiry of lamp-operating life, replace the lamp with lamp holder following with below procedure 1) to 4).

Make sure that the power supply of DC/AC inverter which operates the lamp is turned off before the lamp replacement. Also, please wear fingerstall and be careful not to put any stain or scratch on the LCD panel.

Replacement procedure

- (1) Put the module rear side on the top.
- (2) Slide the edge (shaded area) of the lamp unit to the direction which arrow X indicates.
(The hook "a" of the lamp unit will be unhooked from the hook "b" of the module.)
- (3) Slide the lamp unit to the direction which arrow Y indicates, holding the edge of the lamp unit slided to the direction which arrow X indicates.
- (4) Insert new lamp unit into the LCD module and install the lamp unit until the hook "a" and "b" is engaged.

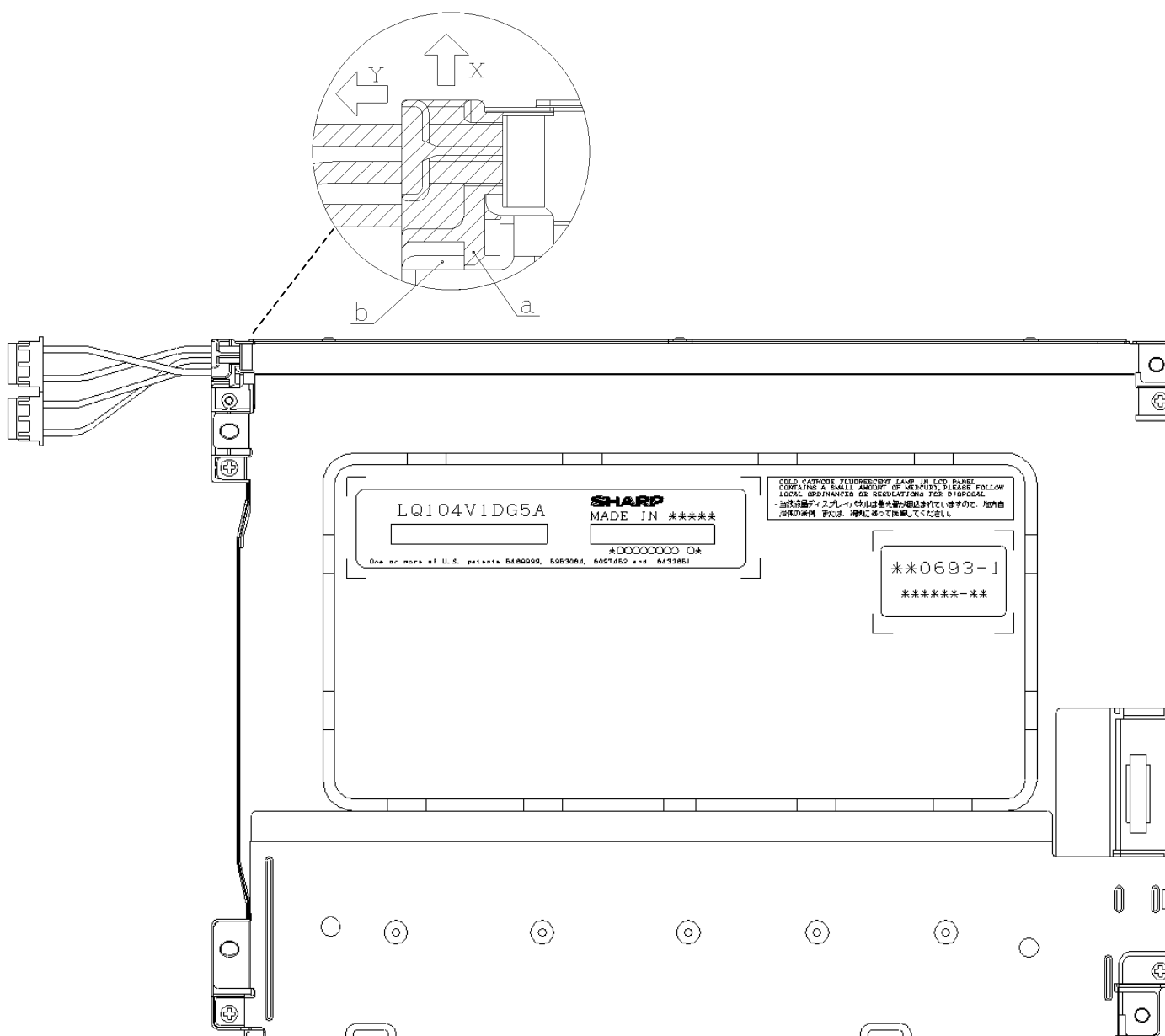

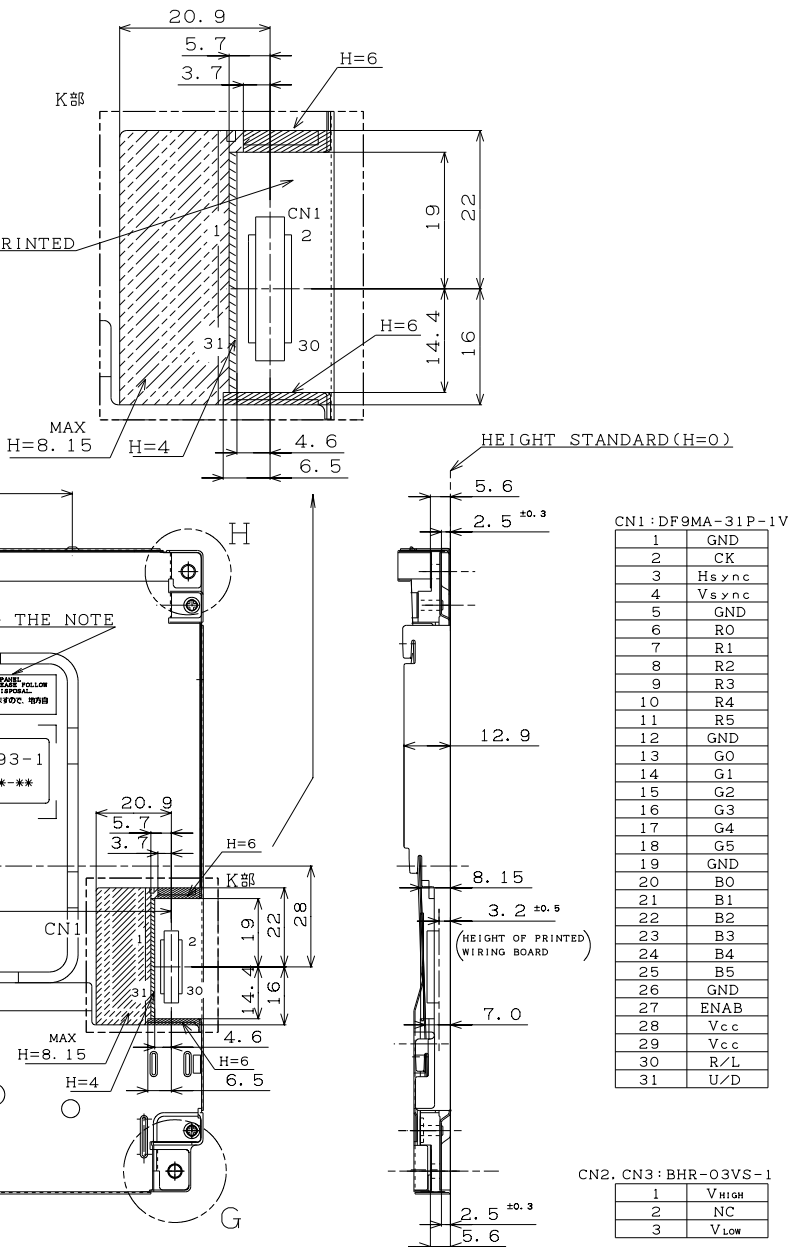
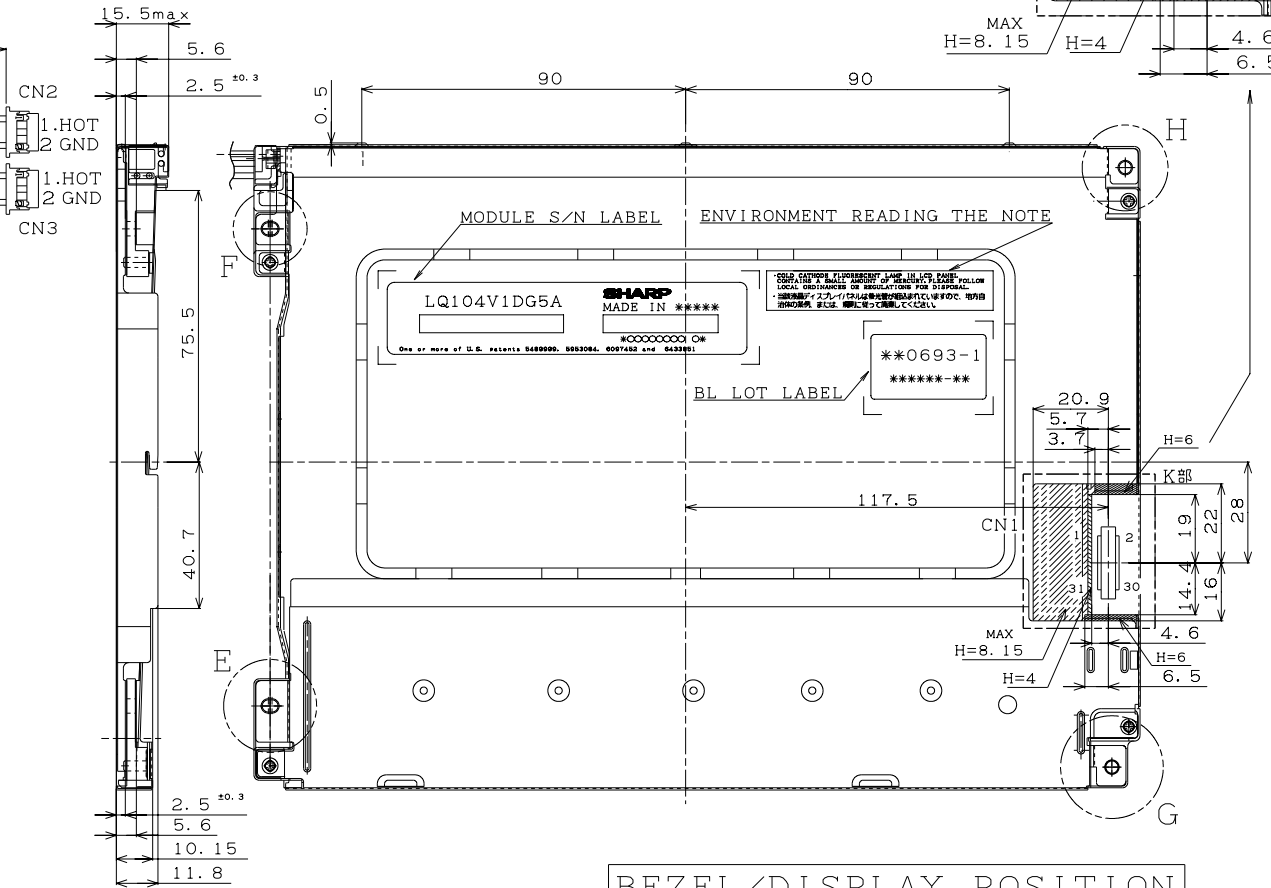
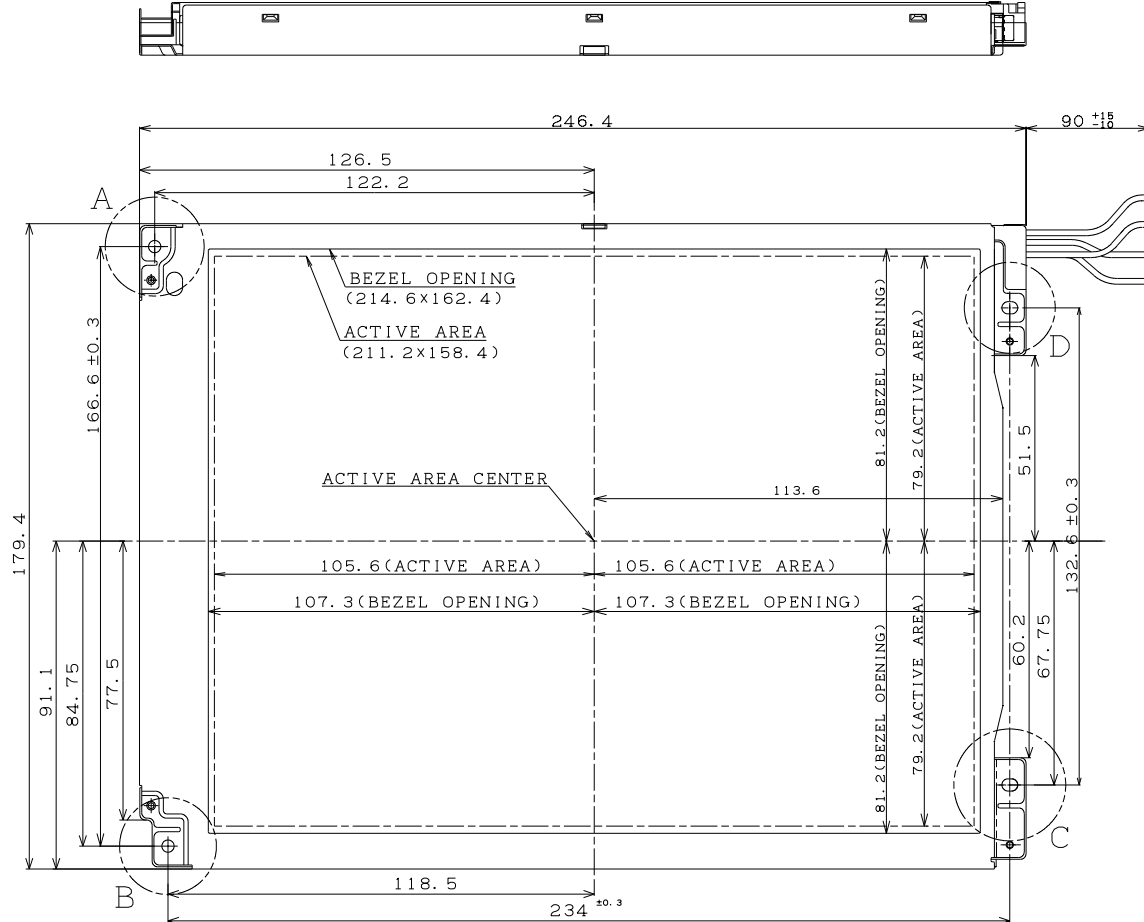
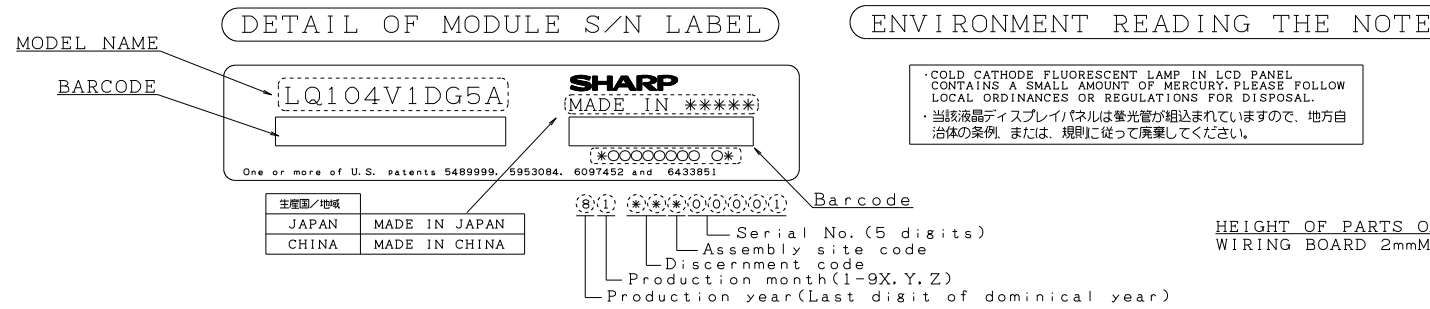

CN1: DF9MA-31P-1V

1	GND
2	CK
3	Hsync
4	Vsync
5	GND
6	RO
7	R1
8	R2
9	R3
10	R4
11	R5
12	GND
13	GO
14	G1
15	G2
16	G3
17	G4
18	G5
19	GND
20	BO
21	B1
22	B2
23	B3
24	B4
25	B5
26	GND
27	ENAB
28	Vcc
29	Vcc
30	R/L
31	U/D

CN2, CN3: BHR-03VS-1

1	V _{HIGH}
2	NC
3	V _{LOW}

BEZEL/DISPLAY POSITION

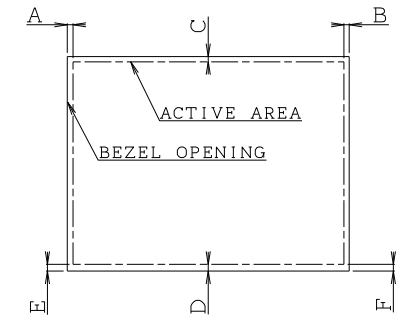

- 1) TOLERANCE X-DIRECTION A: 1.7 ± 0.8
- 2) TOLERANCE X-DIRECTION B: 1.7 ± 0.8
- 3) TOLERANCE Y-DIRECTION C: 2.0 ± 0.8
- 4) TOLERANCE Y-DIRECTION D: 2.0 ± 0.8
- 5) OBLIQUITY OF DISPLAY AREA |E-F| < 0.8

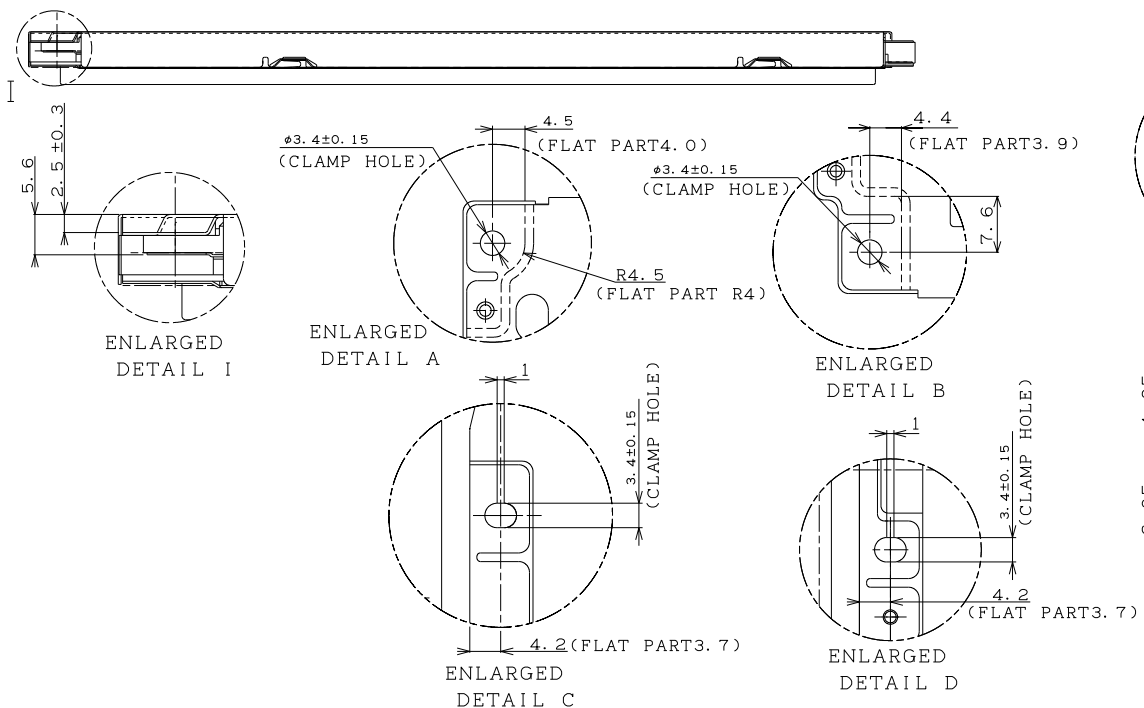

- NOTES**
- 1) UNSPECIFIED TOLERANCE TO BE ± 0.5.
 - 2) WARPING OF COMPONENTS SUCH AS TAPE, BEZEL, PCB, CHASSIS, FPC, PROTECTION COVER, ETC. ARE EXCLUDED FROM THICKNESS AND DIMENSIONS OF THE MODULE.
 - 3) FRONT SIDE: REGARDING THE HEIGHT OF USER'S BOSSES, PLEASE DESIGN THEM FROM φ6mm TO φ7mm.
 - 4) REAR SIDE: REGARDING THE HEIGHT OF USER'S BOSSES, PLEASE DESIGN THEM FROM φ6mm TO φ7.5mm.

LQ104V1DG5A OUTLINE DIMENSIONS

MASTER CARTON

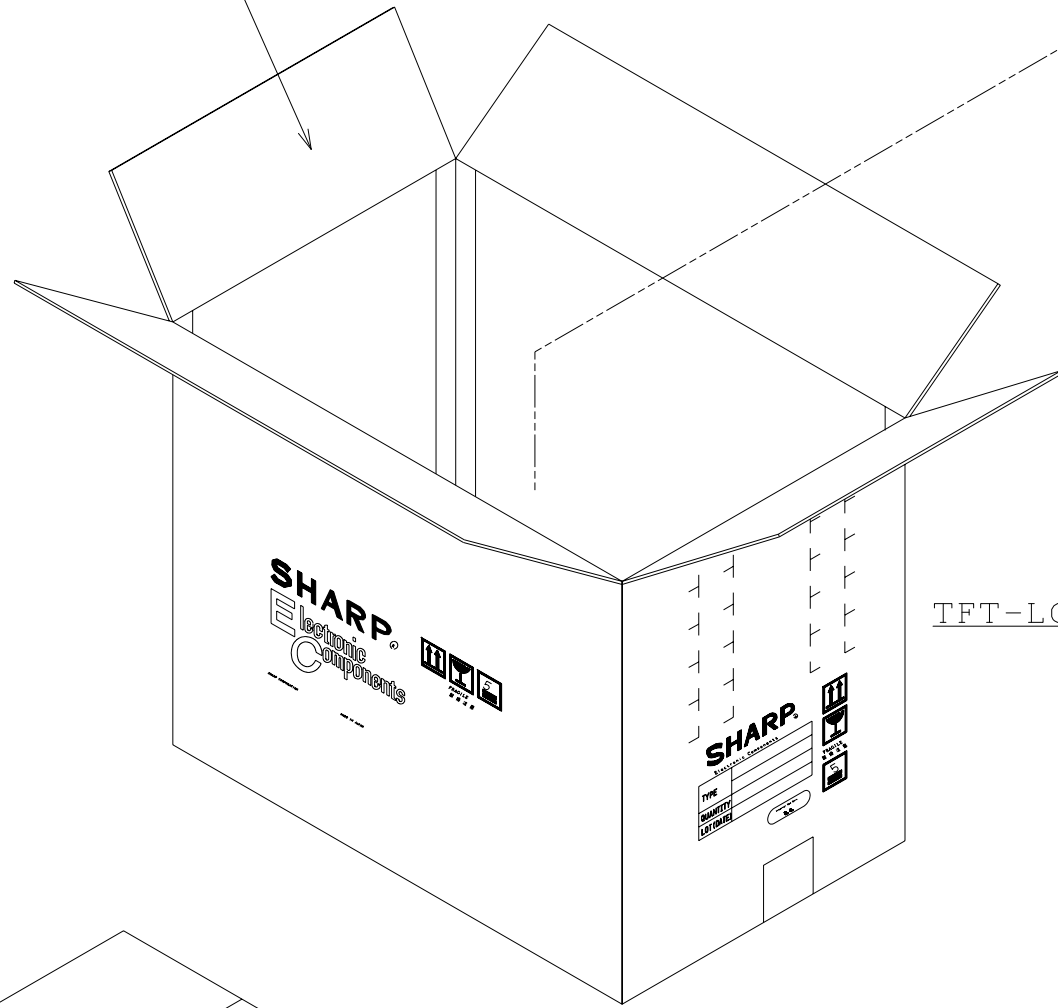

TOP PAD

CORRUGATED FIBER BOARD (TRAY)

TFT-LCD MODULE

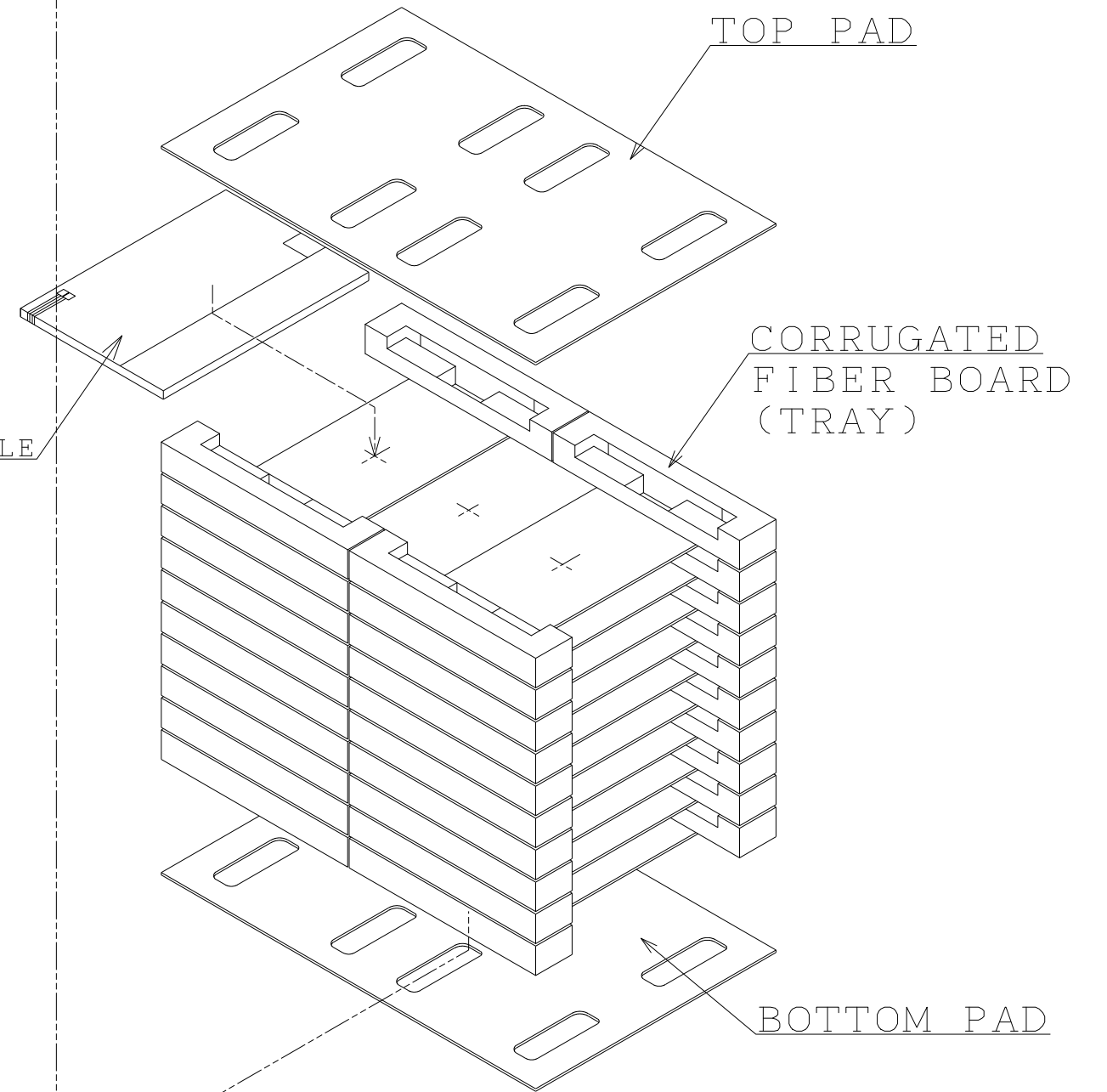

OPP TAPE

PP BAND

S/N LABEL

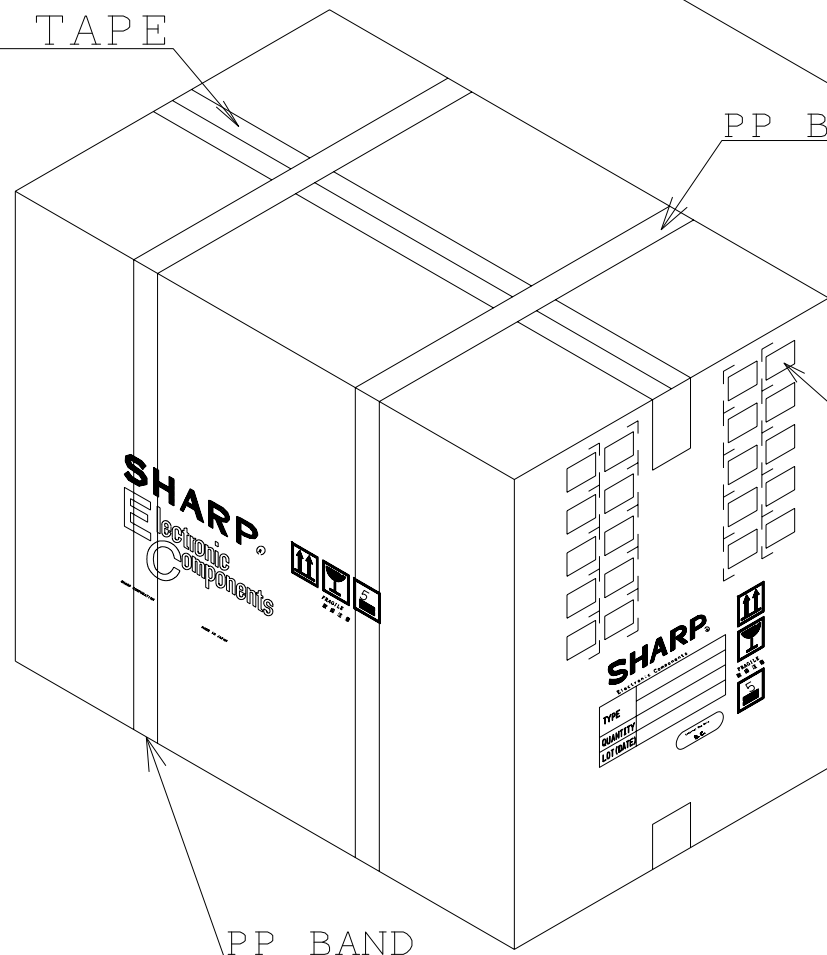

PP BAND

< PACKING FORM >

LCD Specification

LCD Group



NORTH AMERICA

Sharp Microelectronics of the Americas
5700 NW Pacific Rim Blvd.
Camas, WA 98607, U.S.A.
Phone: (1) 360-834-2500
Fax: (1) 360-834-8903
www.sharpsma.com

TAIWAN

Sharp Electronic Components
(Taiwan) Corporation
8F-A, No. 16, Sec. 4, Nanking E. Rd.
Taipei, Taiwan, Republic of China
Phone: (886) 2-2577-7341
Fax: (886) 2-2577-7326/2-2577-7328

CHINA

Sharp Microelectronics of China
(Shanghai) Co., Ltd.
28 Xin Jin Qiao Road King Tower 16F
Pudong Shanghai, 201206 P.R. China
Phone: (86) 21-5854-7710/21-5834-6056
Fax: (86) 21-5854-4340/21-5834-6057
Head Office:
No. 360, Bashen Road,
Xin Development Bldg. 22
Waigaoqiao Free Trade Zone Shanghai
200131 P.R. China
Email: smc@china.global.sharp.co.jp

EUROPE

Sharp Microelectronics Europe
Division of Sharp Electronics (Europe) GmbH
Sonninstrasse 3
20097 Hamburg, Germany
Phone: (49) 40-2376-2286
Fax: (49) 40-2376-2232
www.sharpsme.com

SINGAPORE

Sharp Electronics (Singapore) PTE., Ltd.
438A, Alexandra Road, #05-01/02
Alexandra Technopark,
Singapore 119967
Phone: (65) 271-3566
Fax: (65) 271-3855

KOREA

Sharp Electronic Components
(Korea) Corporation
RM 501 Geosung B/D, 541
Dohwa-dong, Mapo-ku
Seoul 121-701, Korea
Phone: (82) 2-711-5813 ~ 8
Fax: (82) 2-711-5819

JAPAN

Sharp Corporation
Electronic Components & Devices
22-22 Nagaik-cho, Abeno-Ku
Osaka 545-8522, Japan
Phone: (81) 6-6621-1221
Fax: (81) 6117-725300/6117-725301
www.sharp-world.com

HONG KONG

Sharp-Roxy (Hong Kong) Ltd.
3rd Business Division,
17/F, Admiralty Centre, Tower 1
18 Harcourt Road, Hong Kong
Phone: (852) 28229311
Fax: (852) 28660779
www.sharp.com.hk
Shenzhen Representative Office:
Room 13B1, Tower C,
Electronics Science & Technology Building
Shen Nan Zhong Road
Shenzhen, P.R. China
Phone: (86) 755-3273731
Fax: (86) 755-3273735

SPECIFICATIONS ARE SUBJECT TO CHANGE WITHOUT NOTICE.

Suggested applications (if any) are for standard use; See Important Restrictions for limitations on special applications. See Limited Warranty for SHARP's product warranty. The Limited Warranty is in lieu, and exclusive of, all other warranties, express or implied.

ALL EXPRESS AND IMPLIED WARRANTIES, INCLUDING THE WARRANTIES OF MERCHANTABILITY, FITNESS FOR USE AND FITNESS FOR A PARTICULAR PURPOSE, ARE SPECIFICALLY EXCLUDED. In no event will SHARP be liable, or responsible in any way, for any incidental or consequential economic or property damage.